

Operators Manual



STB SERIES Jetter Trailer

Model	PSI	GPM	HP
STB 2511H	2500	11.0	24 Honda

Thank you

Thank you for selecting our products. Our personnel have proudly made every effort to ensure that your new pressure washer is of the quality you expect. But things do occasionally go wrong. This is why every pressure washer is covered by a limited warranty. Among other things, this warranty provides for the replacement of parts found to be defective during the operation of your new pressure washer. Please note that the owner/operator has certain obligations under the terms of the warranty. Be sure to read this manual for directions on proper installation, start-up, use, and storage of your pressure washer.

Your new pressure washer was tested after production for proper pressure and flow. Please note that this process will sometimes leave a water residue in the pump. The dealer you have purchased your new machine from should review with you the proper installation, start-up, use, and storage. Most 'big' problems occur when shortcuts are taken in one of these processes. If a problem occurs that you need some assistance with, please feel free to contact us at the listing below:

Warranty Service Center
520 Brooks Road
Iowa Falls, IA 50126
1.800.648.6007

Please make note of Model Identification

Model # _____

Code # _____

Serial # _____

**Always have this information when calling
Warranty Service Center.**

Be familiar with the model plate located on your machine. Have the model and code number with you when you call for service. (Located on engine).



WARNING

Engine exhaust from this product contains chemicals known to the State of California to cause cancer, birth defects, or other reproductive harm.

Statement of Warranty

The manufacturer of this product agrees to repair or replace designated parts that prove defective within the warranty period listed in the chart below. Specific limitations and exclusions apply. This warranty covers defects in material and workmanship and not failure due to normal wear, depreciation, abuse, accidental damage, negligence, improper use, maintenance or storage. To make claim under the terms of the warranty, all parts said to be defective must be returned to a designated Warranty Service Center for warranty inspection. The judgments and decisions of the factory-authorized personnel concerning the validity of warranty claims are final.

Many components are covered by warranties given by their respective manufacturers. These warranties pass through to the end user. As a factory authorized and trained warranty service center the factory will honor the terms of all component warranties and satisfy claims of the appropriate warranty provisions.

Normal wear items include but are not limited to: hoses, nozzles, filter, valves, seals and are not covered by this warranty.

This warranty is in lieu of all other warranties, express or implied, including without limitation any warranties of merchantability or fitness for a particular purpose and all such warranties are hereby disclaimed and excluded by the Manufacturer. The Manufacturer's warranty obligation is limited to repair and replacement of defective products as provided herein and the Manufacturer shall not be liable for any further loss, damages or expenses, including damages from shipping, accident, abuse, acts of God, misuse or neglect. Neither is damage from repairs using parts not purchased from the Manufacturer or alterations performed by non-factory authorized personnel. Failure to install and operate equipment according to the guidelines put forth in the instruction manual shall void warranty.

Manufacturer	Warranty Period and Details
AR Pump	2 year 1 year on Pump/Motor units
Cat Pump	5 year on 2SF and 4SF models 2 year on 5DX models
General Pump	5 year on pumps Lifetime on brass manifold against freezing 1 year on the aluminum manifold 1 year on Pump/Motor units
Udor Pumps	5 year
Briggs and Stratton	1 year on standard engines 2 year on Intek and Vanguard products
Hatz Diesel Engines	1 year
Honda Engines	2 year on GX series Engines 2 year on GC products for personal use 90 days on GC products in commercial use
Robin Engines	2 year
Baldor Electric Motors	1 year from date of purchase
Leeson Electric Motors	1 year from date of purchase
Burners	1 Year from date of purchase
Hot Water Coils	5 year from date of purchase
Machine Frame	1 year from date of purchase

Accessories: Includes tips, guns, wands, hoses, injectors, unloaders, sandblasters, flat surface cleaners, hose reels, turbo nozzles, drain nozzles, brushes, foamers, GFCI units, thermal relief, filters, tanks, etc. 90 days



WARNING

The following warnings must be followed. Failure to follow these warnings could result in serious personal injury or death!

Never allow children or untrained personnel to operate machinery.



CAUTION

Gun kicks back--hold with both hands.



High pressure water can cause death or serious injury.

Wear protective clothing and face shield.
Do not direct water stream toward self or others.
Do not spray electrical apparatus.

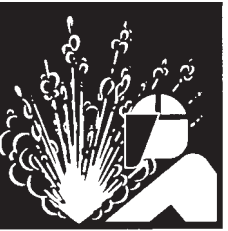

Pressurized fluid streams and ruptured pressure vessels can cause death or serious injury.

High pressure fluid can create a high-pressure stream or ruptured vessel.
Wear safety face shield.
Relieve pressure before servicing.
Do not modify/repair/rework vessel or change safety relief or pressure setting.
Do not direct stream toward self or others.



Exhaust fumes contain harmful gases.
Use in open, well ventilated areas or vent the exhaust to the outside.

Exhaust gases can cause death or serious injury.

Important Safety Instructions

WARNING - when using this product, the following basic precautions should always be followed:

1. Read all the instructions before using the product.
2. To reduce the risk of injury, close supervision is necessary when a product is used near children.
3. Know how to stop the product and bleed pressure quickly. Be thoroughly familiar with the controls.
4. Stay alert--watch what you are doing.
5. Do not operate the product when fatigued or under the influence of alcohol or drugs.
6. Keep operating area clear of all persons.
7. Do not overreach or stand on unstable support. Keep good footing and balance at all times.
8. Follow the maintenance instructions specified in the manual.
9. **WARNING** - Risk of injection or injury--do not direct discharge stream at persons.

Save these instructions

Initial setup and operation of your new jetter/pressure washer

Inspection for freight damage When you receive your pressure washer, be sure you check for concealed freight damage. Any damage should be noted with the delivering carrier. If you have any questions related to freight, call the 800 number listed on the inside front cover of the manual.

Inspection of oil levels Check all oil levels in the pump or engine, if applicable. Failure to check all levels will result in equipment damage. Most pumps are shipped with oil from the factory and the crankcase is sealed. You may have to remove a shipping plug and install a dipstick in the pump.

Water supply Your machine is equipped with a float switch located by the outlet of the water tank. An adequate amount of water must be in the tank (60 gal.) in order for the engine to start. This will prevent the pump from being run dry. The garden hose provided is to be used as a way to fill the 300 gal. water tank and as a supplement water supply. **The flow from the garden hose alone will not provide an adequate amount of water to the machine.** The machine will run approximately 25 min. of continuous run time on a full tank of water. Your water supply must provide water to the equipment that exceeds the Gallon Per Minute (GPM) rate of your machine. The water temperature cannot exceed 145 degrees Fahrenheit. Pressure should not exceed 60 PSI. **Failure to secure adequate water supply will result in pump damage. Do not run pump dry!**

Supply hose **Many states require a vacuum break or backflow preventor be installed at the hydrant, before the garden hose, to insure the water source cannot be contaminated. Be sure to check local and state regulations upon installation.**

Water quality Your water supply should not contain particles larger than 80 microns. Although there are small filters installed on pressure washers that filter the water, they can only filter poor quality water for a short period of time before clogging. This will result in damage to the machine. Therefore, you should insure no sand or scale particles are present in the water supply.

Water leaks Look for water leaks and stop any leak found. Leaks can cause erratic pump behavior.

Pump/engine Prior to starting the engine, check the oil in the engine and pump. Be sure they are at proper operating levels and the correct oil for the conditions. Check your engine manual for oil type and conditions and the pump breakdown for proper oil for the pump. Be sure your engine is full of fresh, clean fuel.

Throttle control Your engine is equipped with a **throttle control** knob located on the discharge hose reel. This allows the engine RPM to be adjusted incrementally by rotating the black knob, or by depressing the red button to achieve engine idle or full engine RPM.

Starting engine Start your engine following the instructions in the engine manual. Be familiar with choke, shut-off switch, as well as inlet and discharge ball valves, before starting engine. Allow engine to warm for one to two minutes before operating jetter. Before shutting down, run engine at idle for one to two minutes. This is achieved by shutting off valve on discharge hose reel (pg. 10), allowing machine to run in by-pass mode



WARNING

In drain jetting applications, *the hose must be inserted into the drain line at least five feet before starting water flow.* Be sure machine is not powered on before hose is inserted into the drain. Be sure machine is shut down before removing the hose from the drain. Always be sure hose is marked at the point five feet from the nozzle to identify nozzle position.

During operation

The pressure was set at the factory during the testing procedure; no adjustments to the machine should be required for operation.

Accessory operation

 **WARNING** Use extreme caution when attaching devices to the discharge of this equipment. Allow only trained individuals to operate this machinery. The attachments must be rated to operate within the pressure range of the equipment or injury could occur. Only use attachments designed, rated, and sized for the equipment by the manufacturer.

Hose and reels The discharge hoses and fittings should be inspected before every use. Also inspect the connections and swivels located on the hose reels. Be sure to unlock the hose reel before using electric controls.

Hose size considerations Remember, when selecting a hose, the smaller diameter and longer the hose, the greater the pressure and flow loss will be. Do not couple hoses together for drain jetting. The long couplings will get caught in bends in the drain lines.

Shut off valve When drain jetting, always attach a shut-off valve, trigger gun, or foot valve directly to the hose to be inserted in the drain. This ensures safe shut-off of the water flow at the user's discretion.

 **WARNING** In drain jetting applications, ***the hose must be inserted into the drain line at least five feet before starting water flow.*** Be sure machine is not powered on before hose is inserted into the drain. Be sure machine is shut down before removing the hose from the drain. Always be sure hose is marked at the point five feet from the nozzle to identify nozzle position.

Nozzles The nozzle, or tip, provided with the machine, is used to match the discharge water flow to achieve the rated operating pressure of the equipment. Only use a properly sized nozzle for your equipment. The nozzle should be inspected before every use for obstructions and nozzle wear.

Jetter operating procedure

Starting engine

1. Water level must be high enough to open float switch (approximately half full) (see page 10).
2. Open inlet ball valve (see page 8).
3. Remove drain nozzle from hose.
4. Insert jetter hose **a minimum of 5'** into the drain and secure. ***Failure to secure hose may result in personal injury or death.***
5. Open discharge valve on the reel (see page 10).
6. Start your engine and allow pump to prime until all air is purged from hose and you have a good solid stream of water from hose.
7. Shut off the water flow with the discharge valve and reinstall your drain nozzle.
8. Allow engine to warm up in this position for 1 - 2 minutes.
9. Reinsert jetter hose **a minimum of 5'** into the drain and secure. ***Failure to secure hose may result in personal injury or death.***
10. You are now ready to begin jetting.



Pulsar valve

The pulsar valve is located on the center inlet valve of your pump (see page 8). Turning valve knob clockwise will disable the center cylinder of the pump, causing the hose to vibrate or pulse. The pulse feature is very helpful when executing long runs, tight blockages or maneuvering corners. *For best results keep as much hose as possible either down the drain or snug on the reel.* Having the hose snug on the reel will greatly increase the effectiveness of the pulse valve.

Shut-down procedure

Storage

1. Turn off the power switch on the pressure washer.
2. Relieve pressure on line by opening valve.
3. Shut off water supply and disconnect garden hose.
4. Be sure to check for water leaks or oil leaks that should be repaired before the next operation.
5. If you are going to store the machine for extended periods of time in cold climates be sure to anti-freeze the equipment or purge system with air using blow out valve installed on pump. A 50% anti-freeze solution may be drawn in through the inlet of the pump using a short remnant of garden hose. This fluid should be run through the pump. When the fluid is discharged from the pump discharge your machine is winterized. **Do not allow machine to freeze.**

Pump/gearbox

The pump/gearbox oil should be changed after the first 50 hours of operation. Then change every year after that for average use. Oil should be changed more frequently for extensive use or use in dusty areas or areas with high moisture. Pump uses 30 wt. oil, gearbox uses 80-90 wt.

Engine

If the engine is to be stored for an extended length of time, a fuel stabilizer is highly recommended. Failure to use a fuel stabilizer may result in varnishing in the carburetor or injector's and will require servicing to make the engine run.

Filters

Water filters, hoses, and fittings should be checked prior to every operation for cleanliness, leaks, and needed repair or replacement.

Troubleshooting

Despite the complexity of your jetter, a number of common complaints stem from relatively simple problems. With guidance, the user can identify and remedy many common problems.

Always disconnect the power supply before attempting to service any equipment.

Common problems and solutions

Malfunction	Cause	Remedy
Unit runs but no water discharges	<ul style="list-style-type: none">-Water supply not turned on-Plugged nozzle on discharge-Shut off valve is malfunctioning	<ul style="list-style-type: none">-Turn on water supply-Remove, clean, or replace nozzle-Remove, repair, or replace valve
Low nozzle pressure	<ul style="list-style-type: none">-Plugged spray nozzle-Inlet screen is plugged-Insufficient water supply-Unloader valve stuck open-Plugged inlet or discharge hose-Use of additional lengths of hose	<ul style="list-style-type: none">-Remove and clean or replace nozzle-Remove and clean or replace filter-Secure adequate water supply-Disassemble and clean, repair, or replace-Flush or replace hoses-Reduce discharge hose length
Surging pressure or drop in pressure	<ul style="list-style-type: none">-Partially plugged spray nozzle-Worn nozzle-Restricted or leaking inlet hose, filter-Cavitation (inadequate water supply)-Worn pump seals-Fouled inlet or discharge valves-Broken valve spring-Worn or restricted unloader valve	<ul style="list-style-type: none">-Remove and clean or replace nozzle-Remove and replace nozzle-Check inlet hose, filter; clean or replace-Secure adequate water supply-Inspect and replace worn packings-Inspect and clean or replace valves-Inspect and replace valve spring-Inspect, repair, or replace unloader
Pressure at pump but low discharge pressure	<ul style="list-style-type: none">-Restricted discharger	<ul style="list-style-type: none">-Check for discharge obstructions in injector, gun, hose, valve, wand, and unloader.
Water leaks from pump manifold	<ul style="list-style-type: none">-Worn plungers or seals	<ul style="list-style-type: none">-Inspect and replace
Unloader does not bypass	<ul style="list-style-type: none">-All valves fouled-Unloader valve seat fouled	<ul style="list-style-type: none">-Inspect, clean or replace-Inspect, clean or replace Unloader assly.
Unloader cycles when gun is shut off	<ul style="list-style-type: none">-Leak in trigger or discharge line	<ul style="list-style-type: none">-Inspect, repair or replace leaking fittings
Water in crankcase	<ul style="list-style-type: none">-High humidity or direct water spray-Worn seals	<ul style="list-style-type: none">-Reduce oil change intervals-Replace seals

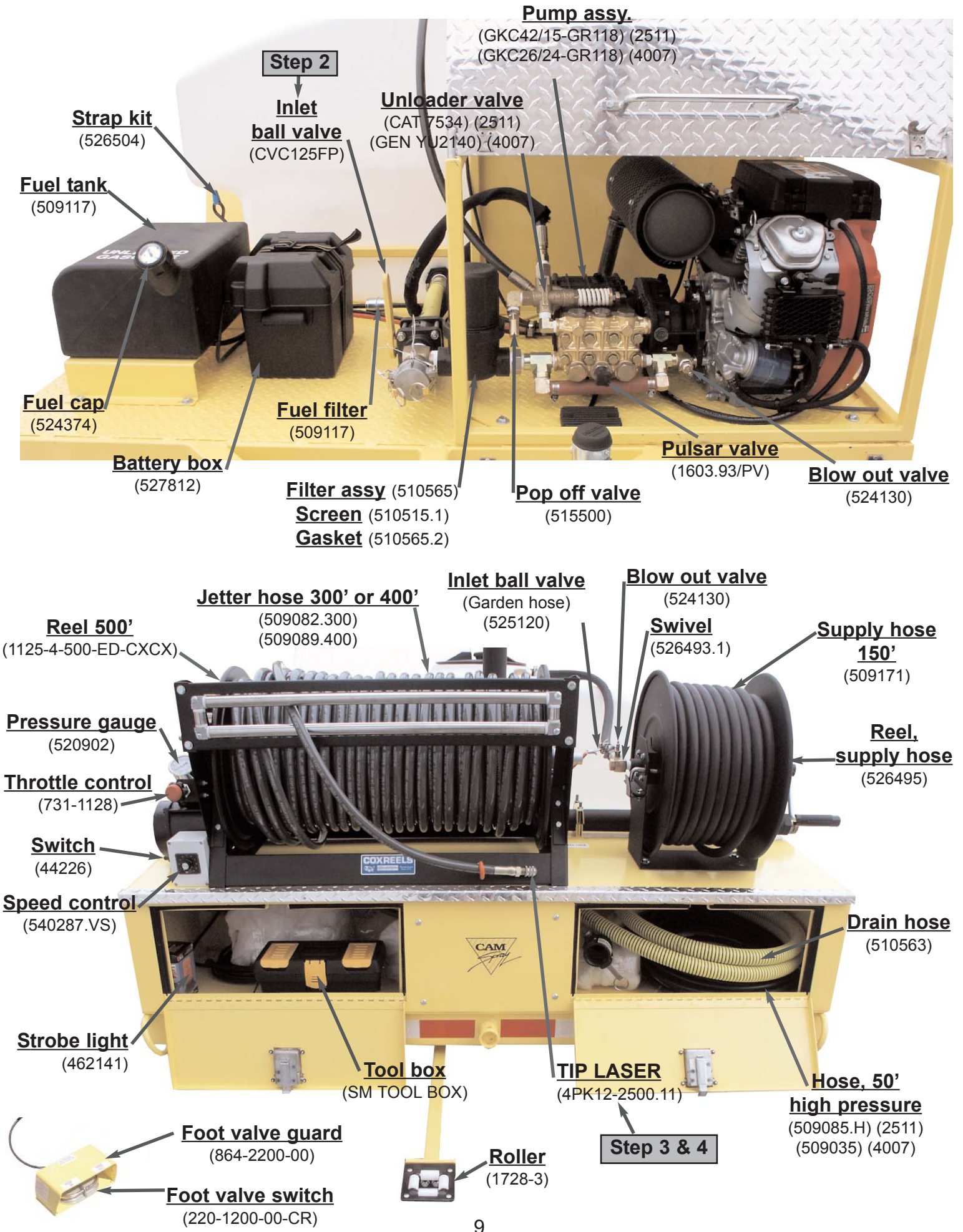

Pump assy.

(GKC42/15-GR118) (2511)
(GKC26/24-GR118) (4007)

Step 2

Inlet ball valve
(CVC125FP)

Unloader valve
(CAT 7534) (2511)
(GEN YU2140) (4007)

Strap kit
(526504)

Fuel tank
(509117)

Fuel cap
(524374)

Battery box
(527812)

Fuel filter
(509117)

Filter assy (510565)
Screen (510515.1)
Gasket (510565.2)

Pop off valve
(515500)

Pulsar valve
(1603.93/PV)

Blow out valve
(524130)

Jetter hose 300' or 400'
(509082.300)
(509089.400)

Inlet ball valve
(Garden hose)
(525120)

Blow out valve
(524130)

Swivel
(526493.1)

Supply hose 150'
(509171)

Reel 500'
(1125-4-500-ED-CXCX)

Pressure gauge
(520902)

Throttle control
(731-1128)

Switch
(44226)

Speed control
(540287.VS)

Reel, supply hose
(526495)

Drain hose
(510563)

Strobe light
(462141)

Tool box
(SM TOOL BOX)

TIP LASER
(4PK12-2500.11)

Hose, 50' high pressure
(509085.H) (2511)
(509035) (4007)

Foot valve guard
(864-2200-00)

Foot valve switch
(220-1200-00-CR)

Roller
(1728-3)

Step 3 & 4

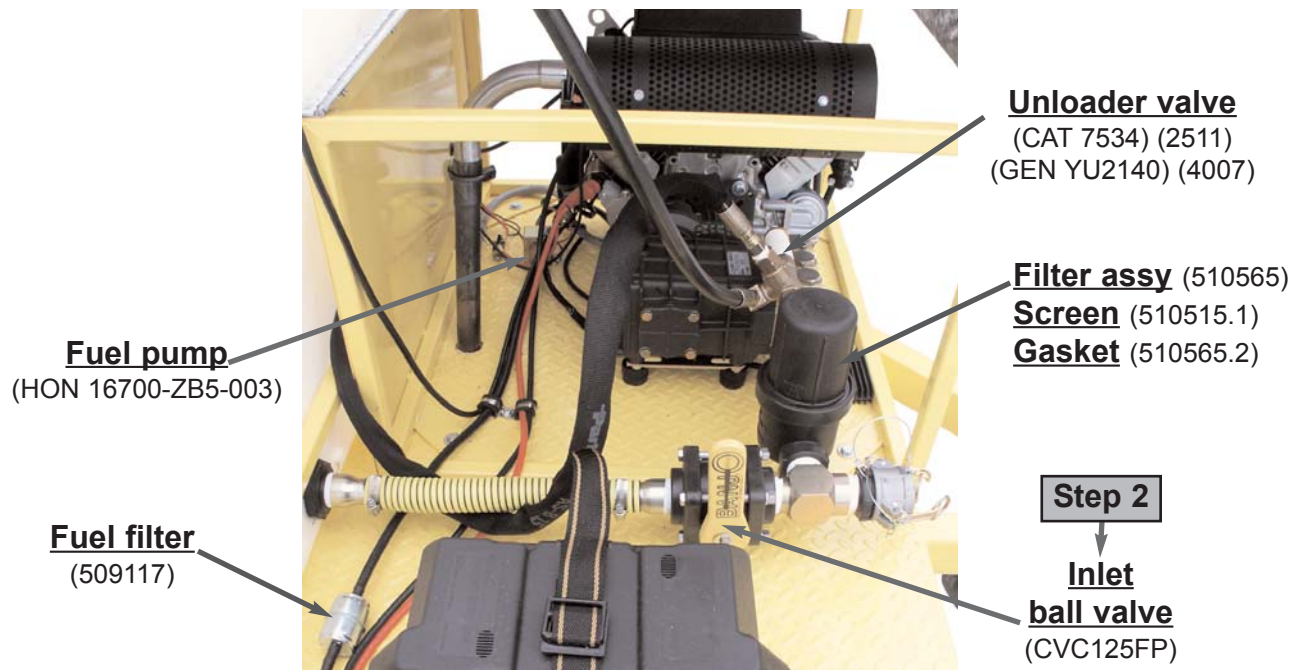
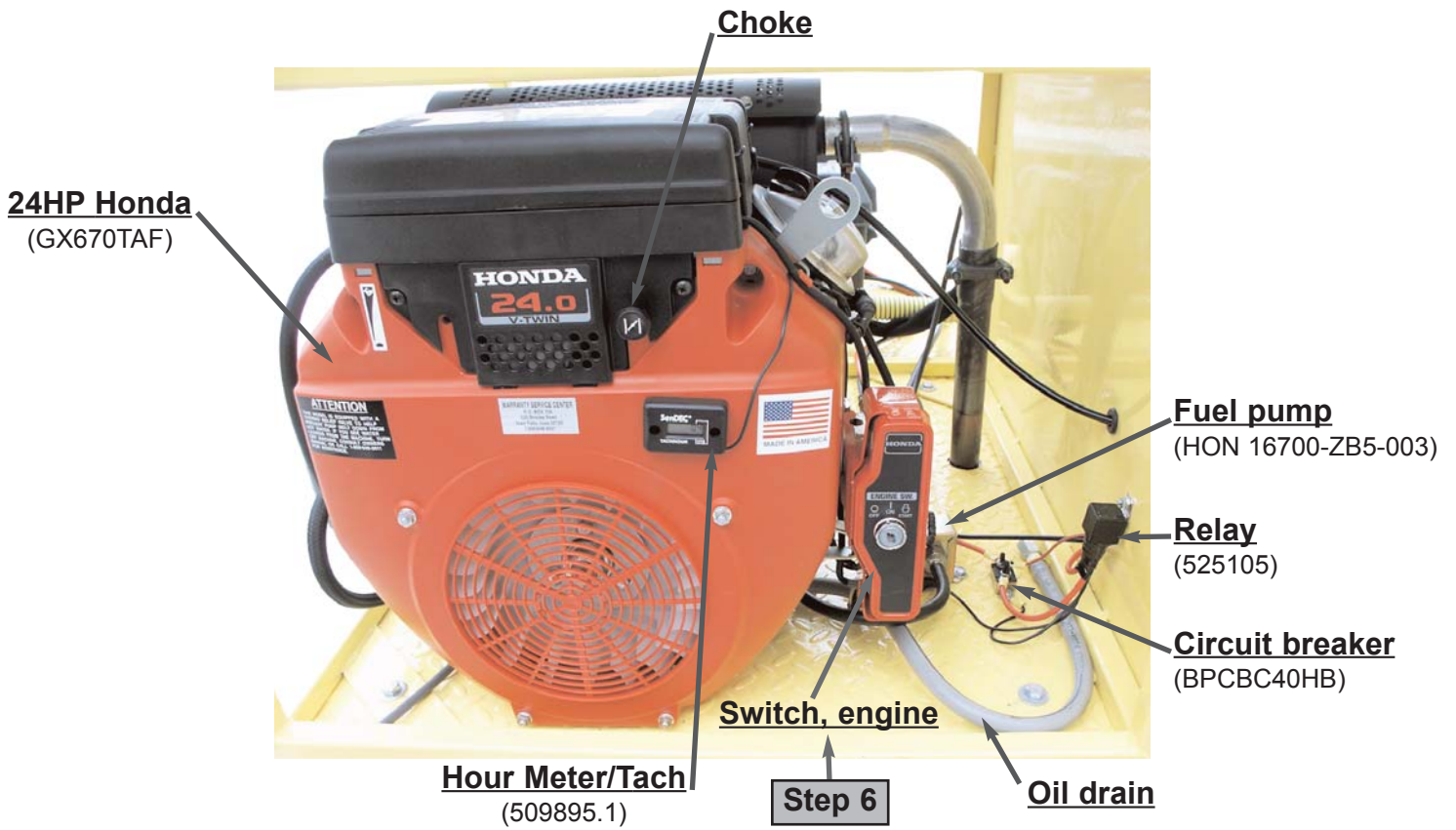

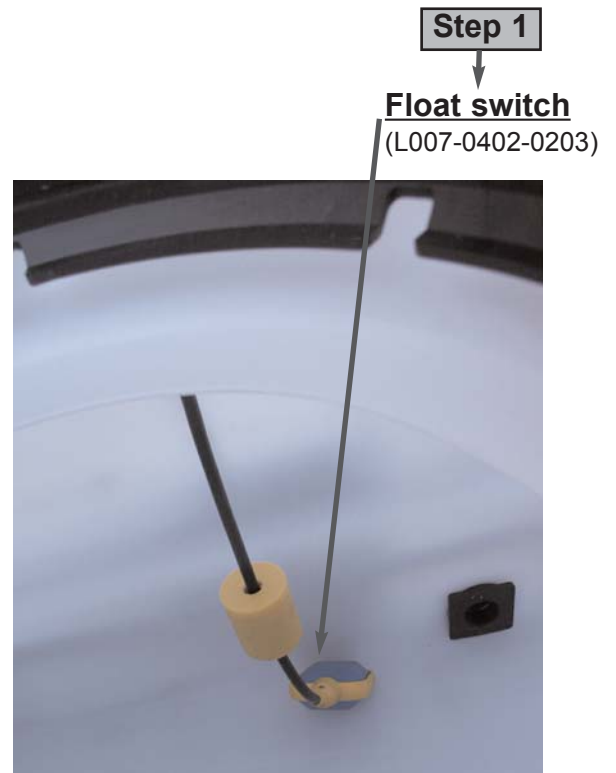
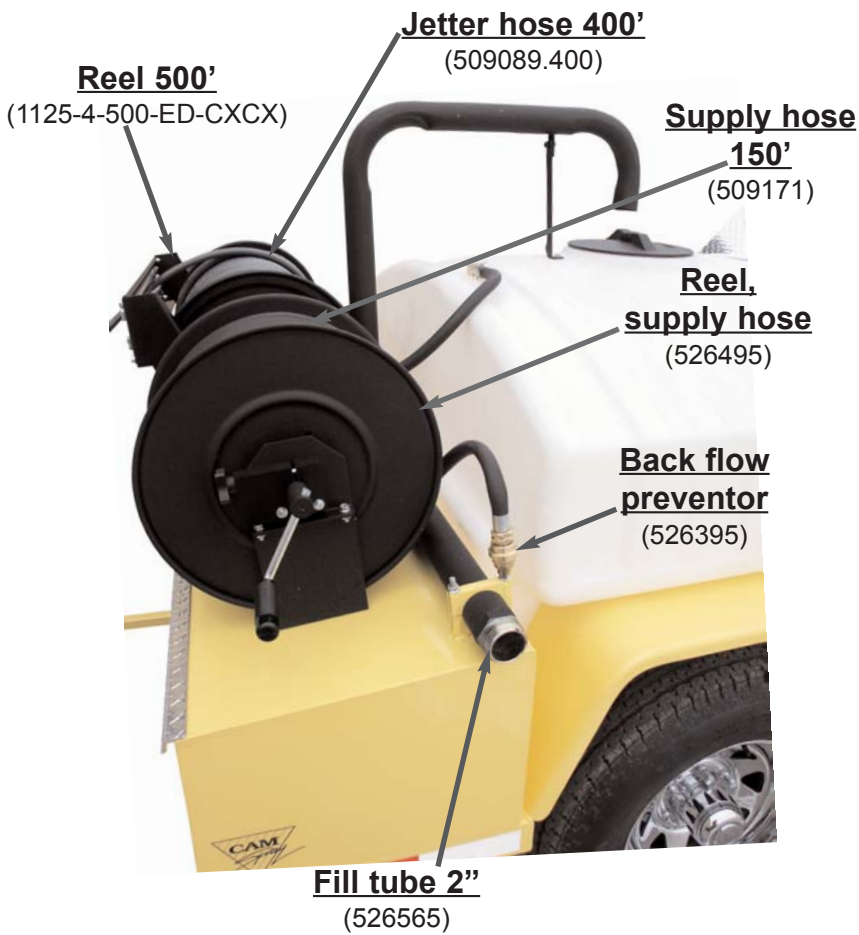
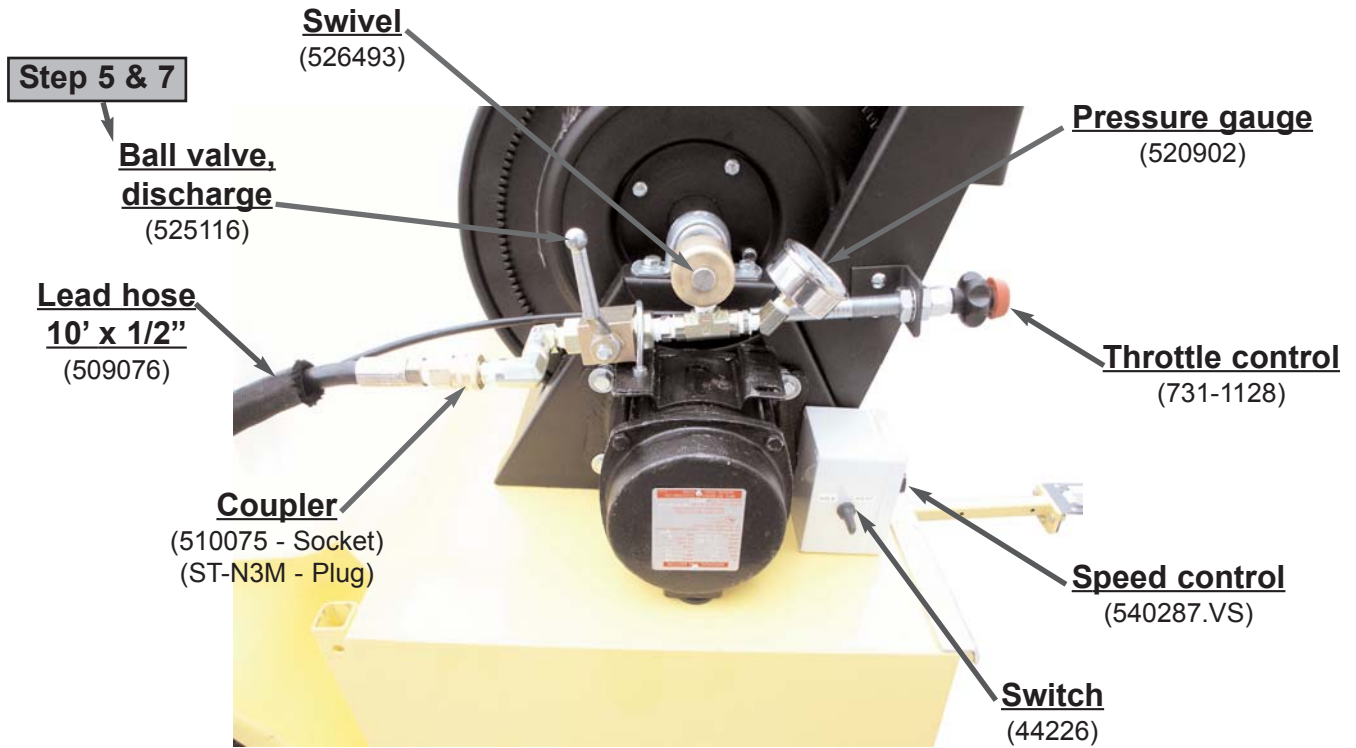

CAT 7534

PARTS LIST

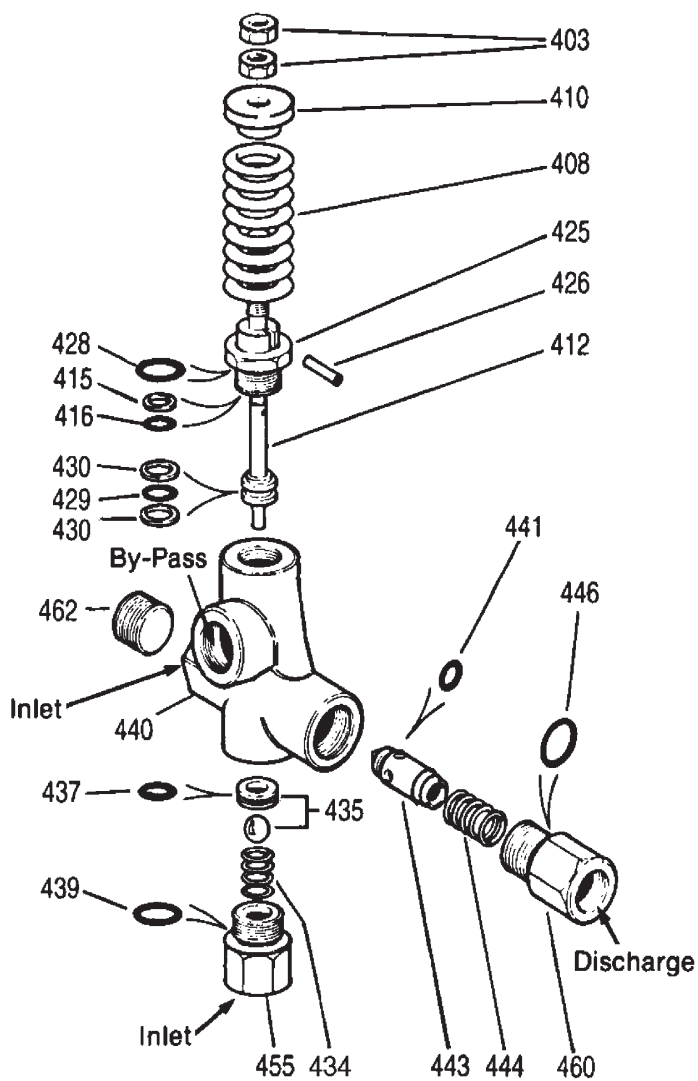

Item	Description	Part no.	Qty
403	Nut, Hex Adjusting	N/A	2
408	Spring-White	N/A	1
410	Guide, Spring	N/A	1
412	Stem, Piston	N/A	1
415	Back-up-Ring, Stem	N/A	1
416	O-Ring, Piston Stem	N/A	1
425	Retainer, Piston	N/A	1
426	Pin, Piston Lock	N/A	1
428	O-Ring, Retainer	N/A	1
429	O-Ring, Piston Stem	N/A	1
430	Back-up-Ring, Stem	N/A	2
434	Spring, Seat	N/A	1
435	Ball and Seat Assembly	N/A	1
437	O-Ring, Seat	N/A	1
439	O-Ring, Inlet Fitting	N/A	1
440	Body	N/A	1
441	O-Ring, Check Valve	N/A	1
443	Valve, Check	32328	1
444	Spring, Check Valve	32332	1
446	O-Ring, Disch Fitting	N/A	1
455	Fitting,, Inlet (1/2" NPT)	32322	1
460	Fitting,, Disch (1/2" NPT)	32331	1
462	Plug, Inlet	N/A	1
468	O-Ring Kit	32346	1

(Kit Incls: 415,416,428,429,430,
437,439,441,446)

Gun/Wand breakdown



Part no.	Description
509374	Gun/wand
509372	Gun
509370	Wand 36"
1515 1/4 MEG	Tip 15 deg.
509085.H	Hose 50' x 3/8" (2511)
509035	Hose 50' x 3/8" (4007)
510070	Coupler plug

