

SERVICE MANUAL

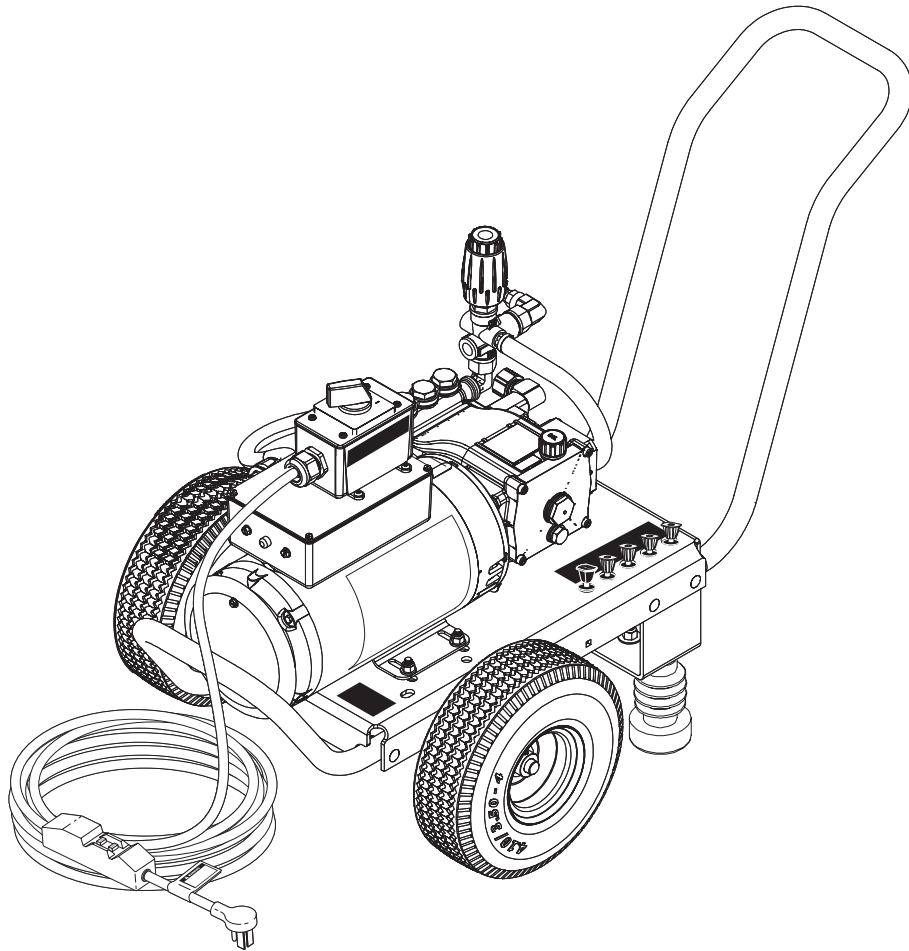

<u>MODEL #</u>	<u>ORDER #</u>
HD 2.0/1000 Ed	1.106-124.0
HD 1.9/1300 Ed	1.106-125.0
HD 3.0/1000 Ea	1.106-126.0
HD 3.5/2000 Ea	1.106-127.0
HD 1.8/1300 Ed	1.106-128.0

CONTENTS

Important Safety Information	4-5
Exploded View	6
Exploded View Parts List	7-8
Pump Assembly, Exploded view	9-10
LF2030S Series Pump Exploded view and part's list	11-12
LF3530F Series Pump Exploded view and part's list	13-14
LF2830S Series Pump Exploded view and part's list	15-16
VRT3 Unloader exploded view and part's list	17
Wiring Diagram	18-21
Troubleshooting	22
Preventative Maintenance	23

INTRODUCTION & IMPORTANT SAFETY INFORMATION

Thank you for purchasing this Pressure Washer.

We reserve the right to make changes at any time without incurring any obligation.

Owner/User Responsibility:

The owner and/or user must have an understanding of the manufacturer's operating instructions and warnings before using this pressure washer. Warning information should be emphasized and understood. If the operator is not fluent in English, the manufacturer's instructions and warnings shall be read to and discussed with the operator in the operator's native language by the purchaser/owner, making sure that the operator comprehends its contents.

Owner and/or user must study and maintain for future reference the manufacturers' instructions.

The operator must know how to stop the machine quickly and understand the operation of all controls. Never permit anyone to operate the engine without proper instructions.

SAVE THESE INSTRUCTIONS

This manual should be considered a permanent part of the machine and should remain with it if machine is resold.

When ordering parts, please specify model and serial number. Use only identical replacement parts.

This machine is to be used only by trained operators.

IMPORTANT SAFETY INFORMATION

! WARNING



READ OPERATOR'S MANUAL THOROUGHLY PRIOR TO USE.

WARNING: To reduce the risk of injury, read operating instructions carefully before using.

1. Read the owner's manual thoroughly. Failure to follow instructions could cause malfunction of the machine and result in death, serious bodily injury and/or property damage.
2. Know how to stop the machine and bleed pressure quickly. Be thoroughly familiar with the controls.

3. Stay alert — watch what you are doing.
4. All installations must comply with local codes. Contact your electrician, plumber, utility company or the selling distributor for specific details. If your machine is rated 250 volts or less, single phase will be provided with a ground fault circuit interrupter (GFCI). If rated more than 250 volts, or more than single phase this product should only be connected to a power supply receptacle protected by a GFCI.

DANGER: Improper connection of the equipment-grounding conductor can result in a risk of electrocution. Check with a qualified electrician or service personnel if you are in doubt as to whether the outlet is properly grounded. Do not modify the plug provided with the product - if it will not fit the outlet, have a proper outlet installed by a qualified electrician. Do not use any type of adaptor with this product

! WARNING



KEEP WATER SPRAY AWAY FROM ELECTRICAL WIRING.

WARNING: Keep wand, hose, and water spray away from electric wiring or fatal electric shock may result.

5. To protect the operator from electrical shock, the machine must be electrically grounded. It is the responsibility of the owner to connect this machine

to a UL grounded receptacle of proper voltage and amperage ratings. Do not spray water on or near electrical components. Do not touch machine with wet hands or while standing in water. Always disconnect power before servicing.

! WARNING



RISK OF EXPLOSION: DO NOT SPRAY FLAMMABLE LIQUIDS.

WARNING: Flammable liquids can create fumes which can ignite, causing property damage or severe injury.

WARNING: Risk of explosion — Do not spray flammable liquids.

6. Do not allow acids, caustic or abrasive fluids to pass through the pump.

7. Never run pump dry or leave spray gun closed longer than 1-2 minutes.
8. Keep operating area clear of all persons.

! WARNING



USE PROTECTIVE EYE WEAR AND CLOTHING WHEN OPERATING THIS EQUIPMENT.

WARNING: High pressure spray can cause paint chips or other particles to become airborne and fly at high speeds. To avoid personal injury, eye, hand and foot safety devices must be worn.

9. Eye, hand, and foot protection must be worn when using this equipment.

IMPORTANT SAFETY INFORMATION

! WARNING



TRIGGER GUN KICKS BACK - HOLD WITH BOTH HANDS

WARNING: Grip cleaning wand securely with both hands before starting. Failure to do this could result in injury from a whipping wand.

! WARNING



RISK OF INJURY FROM FALLS WHEN USING LADDER.

WARNING: Be extremely careful when using a ladder, scaffolding or any other relatively unstable location. The cleaning area should have adequate slopes and drainage to reduce the possibility of a fall due to slippery surfaces.

! WARNING



RISK OF INJECTION OR SEVERE INJURY TO PERSONS. KEEP CLEAR OF NOZZLE.

WARNING: High pressure developed by these machines will cause personal injury or equipment damage. Keep clear of nozzle. Use caution when operating. Do not direct discharge stream at people, or severe injury or death will result.



19. Follow the maintenance instructions specified in the manual.

- 10. To reduce the risk of injury, close supervision is necessary when a machine is used near children. Do not allow children to operate the pressure washer. **This machine must be attended during operation.**
- 11. Never make adjustments on machine while in operation.
- 12. Be certain all quick coupler fittings are secured before using pressure washer.

! WARNING



PROTECT FROM FREEZING

WARNING: Protect machine from freezing.

- 13. To keep machine in best operating conditions, it is important you protect machine from freezing. Failure to protect machine from freezing could cause malfunction of the machine and result in death, serious bodily injury, and/or property damage. Follow storage instructions specified in this manual.
- 14. Inlet water must be clean fresh water and no hotter than 90°F.
- 15. Manufacturer will not be liable for any changes made to our standard machines or any components not purchased from us.
- 16. The best insurance against an accident is precaution and knowledge of the machine.

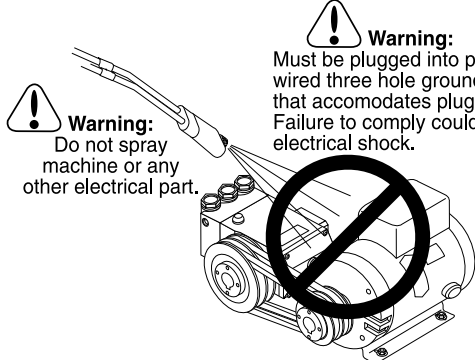

! Warning: Do not spray machine or any other electrical part.

! Warning: Must be plugged into properly wired three hole grounded outlet that accommodates plug on power cord. Failure to comply could result in electrical shock.

EXPLODED VIEW

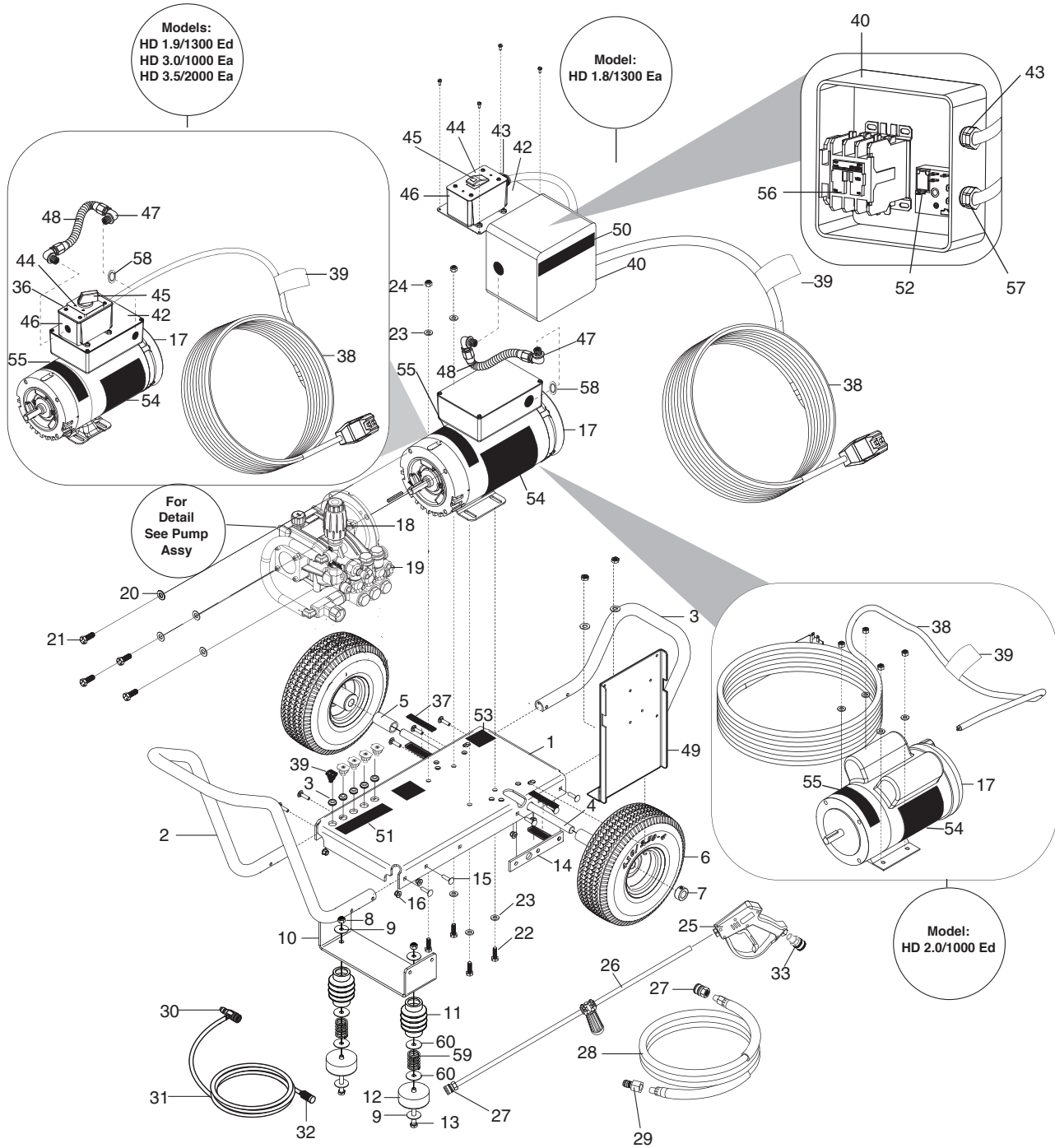

EXPLODED VIEW PARTS LIST

ITEM	PART NO.	DESCRIPTION	QTY
1	8.924-115.0	Al Base Direct Drive	1
2	8.924-394.0	Al Handle	1
3	8.924-393.	Al Bumper	1
4	9.803-097.0	Axle, 5/8 X 20.125 Long	1
5	8.924-179.0	AL Spacer Tube DD Frame	2
6	8.756-365.0	QH Wheel Assy 10", Gray STL RIM, Flat	1
7	9.802-782.0	Collar, 5/8" Bore Shaft 3010	2
8	9.802-776.0	Nut, 5/16-18, ESNA	2
9	9.198-014.0	Washer 21/64 X 1"	4
10	8.928-994.0	Frame Foot Aluminium	1
11	8.706-557.0	Bellows, Leg (BOOT)-P/N	2
12	9.802-066.0	Pad Soft Rubber	2
13	8.754-796.0	Bolt, 5/16-18 X 3 1/2	2
14	8.924-074.0	Camaro Silver Axle Holder DD CW	1
15	9.802-706.0	Bolt, 1/4"-20 x 1-3/4" Carriage Zinc	8
16	9.197-010.0	1/4-20" Nylon Insert Lock Nut With Flange	10
17	9.804-516.0	Motor, 1.5HP 1PH, 115V 1725RPM, TEFC (HD 2.0/1000 Ed)	1
	8.754-709.0	Motor, 2HP, 1PH, 115V, 1750RPM 56C ODP (HD 3.0/1000 Ea, HD 1.9/1300 Ed, HD 1.8/1300 Ed)	1
	9.802-341.0	Motor, 5HP 1PH 208/230V 3450RPM (HD 3.5/2000 Ea)	1
18	8.750-299.0	Unloader, VRT3, 8 GPM @4500 PSI (HD 2.0/1000 Ed, HD 1.9/1300 Ed, HD 3.0/1000 Ea, HD 3.5/2000 Ea)	1
	9.802-362.0	Unloader, PA 8@3650, VB8 W/SWITCH (HD 1.8/1300 Ed)	1
19	8.754-761.0	Pump, Leuco LF2030S, 2.1@3000, 1725RPM (HD 2.0/1000 Ed, HD 1.9/1300 Ed, HD 1.8/1300 Ed)	1
	8.754-763.0	Pump, Leuco LF2830S, 2.8@3000, 1725RPM (HD 3.0/1000 Ea)	1
	8.754-764.0	Pump, Leuco LF3530F, 3.5@3000, 3450RPM (HD 3.5/2000 Ea)	1
20	9.198-004.0	3/8", USS F/W Zinc	4
21	9.802-720.0	Bolt, 3/8" x 1", NC HH	4
22	9.802-710.0	Screw 5/16" x 1" NC	4
23	8.718-980.0	Washer, 5/16" Flat, SAE	8
24	9.802-776.0	Nut, 5/16-18, ESNA	4
25	8.750-247.0	Trigger Gun Model m407	1
26	8.783-039.0	Wand 30" Zinc Plated, Handle & Coupler	1
27	9.802-166.0	Coupler, 3/8" Socket, Female, Brass	2
28	8.916-740.0	Hose, 3/8" x 50', 1w, TS, SOXSW	1
29	9.802-170.0	Coupler, 3/8" Plug, Female, Steel Zinc	1
30	9.802-216.0	Injector, Chem, Non Adj, 0.083	1
31	6.388-216.0	Hose DN 5	3.2 ft.
32	5.731-652.0	Filter with weight	1
33	9.802-169.0	Coupler, 3/8"Socket, Male, Brass	1
34	8.755-187.0	Grommet, Rubber, Nozzle Holder Base 3/16	5
35	8.712-337.0	Nozzle, SAQCMEG, 0003.5, Red (HD 2.0/1000 Ed, HD 1.9/1300 Ed)	1
	8.712-338.0	Nozzle, SAQCMEG 1503.5, Yellow(HD 2.0/1000 Ed, HD 1.9/1300 Ed)	1
	8.712-339.0	Nozzle, SAQCMEG, 2503.5, Green (HD 2.0/1000 Ed, HD 1.9/1300 Ed)	1
	8.712-340.0	Nozzle, SAQCMEG 4003.5, White (HD 2.0/1000 Ed, HD 1.9/1300 Ed)	1
	8.712-357.0	Nozzle, SAQCMEG 0005.5, Red (HD 3.0/1000 Ea)	1
	8.712-358.0	Nozzle, SAQCMEG 1505.5, Yellow (HD 3.0/1000 Ea)	1
	8.712-359.0	Nozzle, SAQCMEG 2505.5, Green (HD 3.0/1000 Ea)	1
	8.712-360.0	Nozzle, SAQCMEG 4005.5, White (HD 3.0/1000 Ea)	1
	8.712-398.0	Nozzle kpl., QCCEM-6540 Mess. (CHEM) (all models)	1

EXPLODED VIEW PARTS LIST

	8.712-353.0	Nozzle, saqcmeg 0005, Red (HD 3.5/2000 ea)	1
	8.712-354.0	Nozzle, saqcmeg 1505, Yellow (HD 3.5/2000 ea)	1
	8.712-355.0	Nozzle, saqcmeg 2505, Green (HD 3.5/2000 ea)	1
	8.712-356.0	Nozzle, saqcmeg 4005, White (HD 3.5/2000 ea)	1
	8.712-331.0	Nozzle, saqcmeg 0003, Red (HD 1.8/1300 ed)	1
	8.712-333.0	Nozzle, saqcmeg 1503, Yellow (HD 1.8/1300 ed)	1
	8.712-334.0	Nozzle, saqcmeg 2503, Green (HD 1.8/1300 ed)	1
	8.712-335.0	Nozzle, saqcmeg 4003, White (HD 1.8/1300 ed)	1
	8.712-398.0	Nozzle kpl., QCEM-6540 Mess. (CHEM)	1
36	9.802-478.0	LID, Plastic, Carlon E9801 Box (HD 3.5/2000 Ea, HD3.0/1000 Ea, HD1.9/1300 Ed)	1
37	9.802-073.0	Weatherstrip, 1/8" x 1/2"	12"
38	9.802-432.0	GFCI, 120V 15A, W/ 36' 12-3 CORD (HD 2.0/1000 ED)	1
	9.802-431.0	GFCI, 125V 20A, 36' 12-3 CORD (HD 1.9/1300 ED, HD 3.0/1000 Ea AND HD 1.8/1300 Ea)	1
	9.802-430.0	GFCI, 240V 1PH 30A, 36' 10-3 CORD (HD 3.5/2000 Ea,)	1
39	8.932-969.0	Label, Warning, Service Cord	1
40	8.716-271.0	Enclosure, Fiberglass, nema4x 14324.500 (HD 1.8/1300 Ea)	1
41	9.802-423.0	Cord, Serv, 16/3, SEOOW, /FT (HD 1.8/1300 Ea)	2 FT
42	9.803-833.0	Cover, Motor (HD 1.8/1300 EA, HD3.5/2000 Ea, HD3.0/1000 Ea, HD1.9/1300 Ed)	1
43	9.802-514.0	Strain Relief, LT, Str, 1/2 NPT, .23-.45D (HD 1.8/1300 Ea)	2
	9.802-518.0	Strain Relief, LT, STR, 3/4 NPT .49-.71D (HD 3.5/2000 Ea, HD3.0/1000 Ea, HD1.9/1300 Ed)	1
44	8.900-840.0	Label, Remote Switch, Home Depot (HD 1.8/1300 Ea)	1
45	9.802-451.0	Switch, Rocker, Carling Green LENS875858 (HD 1.8/1300 Ea)	1
	9.802-450.0	Switch, 2POS. 120V-600V, 1-3PH (HD 3.5/2000 Ea, HD3.0/1000 Ea, HD1.9/1300 Ed)	1
46	9.802-477.0	Box, Plastic, Carlon E9801, W/O LID (HD 1.8/1300 Ea, HD 3.5/2000 Ea, HD3.0/1000 Ea, HD1.9/1300 Ed)	1
47	9.802-517.0	Connector, 1/2" L/T, 90 DGR, Black (HD 1.8/1300 Ea)	2
	9.803-831.0	Connector, 3/4" L/T, 90 DGR, Black (HD 3.5/2000 Ea)	2
48	9.802-448.0	Conduit, WTR. TIGHT, FLEX, 1/2 100'/BOX (HD 1.8/1300 Ea, HD3.0/1000 Ea, HD1.9/1300 Ed)	2.16 FT
	9.802-436.0	Cord, Serv, 10/3, SEOOW, /FT (HD 3.5/2000 Ea)	2.16 FT
49	8.924-750.0	Bracket, Elec Box, HD 1.8/1300Ed (HD 1.8/1300 Ea)	1
50	9.800-016.0	Label, Disconnect Power Supply (HD 1.8/1300 Ea)	1
51	8.755-210.0	Four Nozzle Label, Black (HD 1.8/1300 Ea)	1
52	9.802-472.0	Timer, 24-240v 5-60min w/Lock Out (HD 1.8/1300 Ea)	1
53	9.800-049.0	Label, Manufacturer's cleaning solution (HD 1.8/1300 Ea)	1
54	8.900-305.0	Label, Landa, Home Depot, ZE Warning (HD 1.8/1300 Ea)	1
55	9.800-037.0	Label, French Inst./Warn (HD 1.8/1300 Ea)	1
56	9.802-543.0	Contact, DP, c25dnd225aa, w/aux block (HD 1.8/1300 Ea)	1
57	8.752-969.0	Strain Relief, LT, STR, 1/2 NPT 0.39-0.75ID (HD 1.8/1300 Ea)	1
58	9.803-834.0	Washer, Reducing 3/4" x 1/2"	1
59	5.332-391.0	Pressure spring	2
60	8.719-000.0	Washer, 5/16" x 1-1/4"	4

PUMP ASSEMBLY EXPLODED VIEW

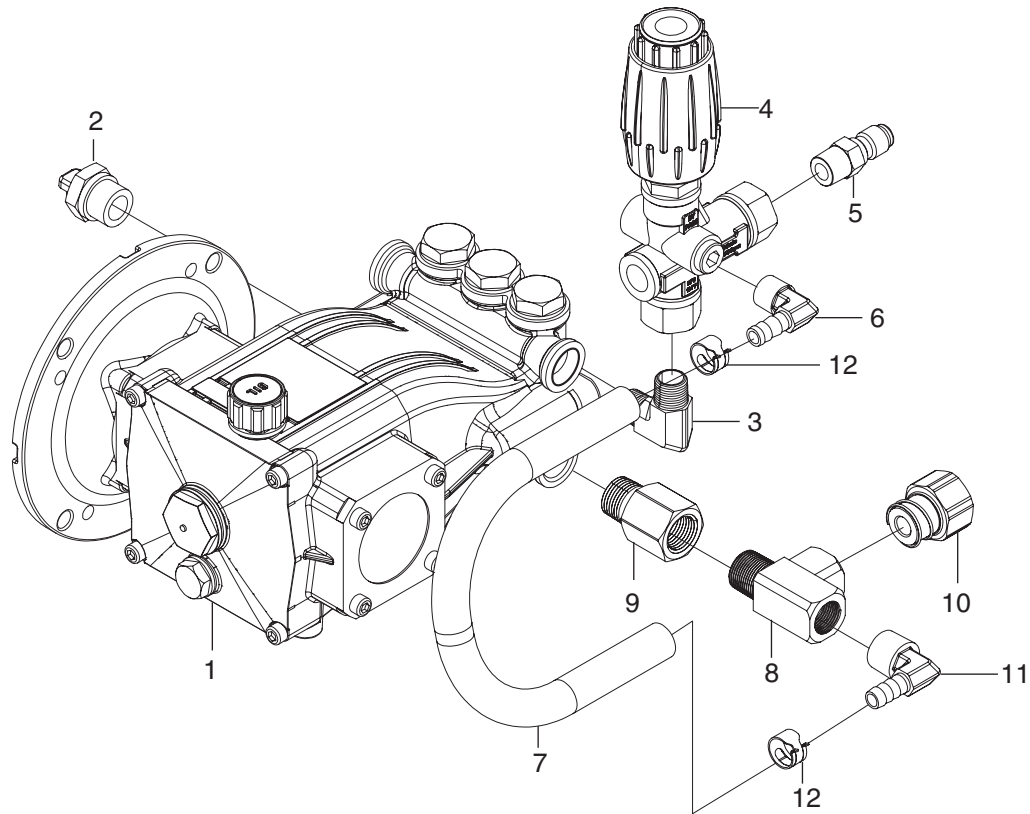

PUMP ASSY EXPLODED VIEW PARTS LIST

ITEM	PART NO.	DESCRIPTION	QTY	ITEM	PART NO.	DESCRIPTION	QTY
1	8.754-761.0	PUMP, LEUCO LF2030S,2.1 @3000, 1725RPM (HD 2.0/1000 Ed, HD 1.9/1300 Ed)	1	11	8.705-120.0	Hosebarb, Elbow, 3/8" Barbx1/2" MPT/ 90Deg	1
	8.754-763.0	PUMP, LEUCO LF2830S, 2.8@3000, 1725RPM (HD 3.0/1000 Ea)	1	12	8.709-117.0	Clamp, Hose, UNI .62-.75 ST	2
	8.754-764.0	PUMP, LEUCO LF3530F, 3.5@3000, 3450RPM (HD 3.5/2000 Ea)	1				
2	8.707-256.0	Pump protector, 1/2"	1				
3	8.706-168.0	Elbow, 3/8" NPT-p/n-tf3529x6 Steel	1				
4	8.750-299.0	Unloader, Vrt3, 8 GPM @4500 psi	1				
5	9.802-171.0	Coupler, 3/8" Clug, Male, Steel/zinc	1				
6	8.705-119.0	Hose Barb, Elbow, 3/8" Barbx3/8" MPT/90Deg	1				
7	8.711-785.0	Hose, 3/8" Push on, per ft	18"				
8	8.706-860.0	Tee, 1/2" Street Brass	1				
9	8.706-984.0	Adapter, 1/2" FTP x 1/2" MPT, brass	1				
10	9.802-146.0	Swivel, 1/2" MP x 3/4" GHF W/Strainer	1				

PUMP ASSEMBLY EXPLODED VIEW

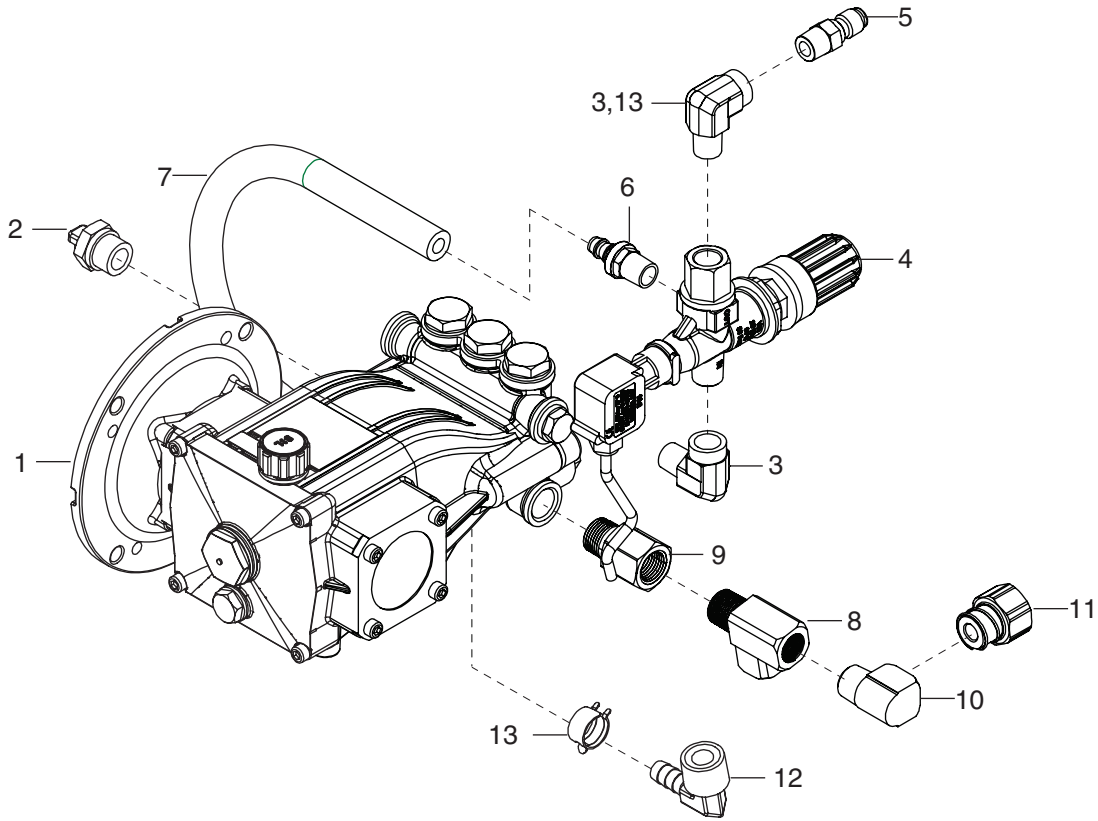

PUMP ASSY EXPLODED VIEW PARTS LIST

ITEM	PART NO.	DESCRIPTION	QTY
1	8.754-761.0	PUMP, LEUCO LF2030S, 2.1@3000, 1725RPM (HD 1.8/1300 Ed)	1
2	8.707-256.0	Pump protector, 1/2"	1
3	8.706-207.0	ELBOW, 3/8", STREET 90 DEG, STEEL	2
4	8.712-720.0	UNLOADER MG4000 3000PSI W/MICR	1
5	9.802-171.0	Coupler, 3/8" Plug, Male, Steel/zinc	1
6	8.706-944.0	Hose Barb, 3/8" barb x 3/8" ML	1
7	8.711-785.0	Hose, 3/8" Push on, per ft	18"
8	8.706-860.0	Tee, 1/2" Street Brass	1
9	8.706-984.0	Adapter, 1/2" FTP x 1/2" MPT, brass	1
10	8.706-829.0	Elbow, 1/2" Street, Brass	1
11	9.802-146.0	Swivel, 1/2" MP x 3/4" GHF W/Strainer	3
12	8.705-120.0	Hosebarb, ELBOW, 3/8" Barbx1/2" MPT/90Deg	1
13	8.706-168.0	Elbow, 3/8" 3/8" MPT-P/N- TF3529X6 Steel	1

LF 2030S SERIES PUMP EXPLODED VIEW

8.924-736.0 LF 2030S

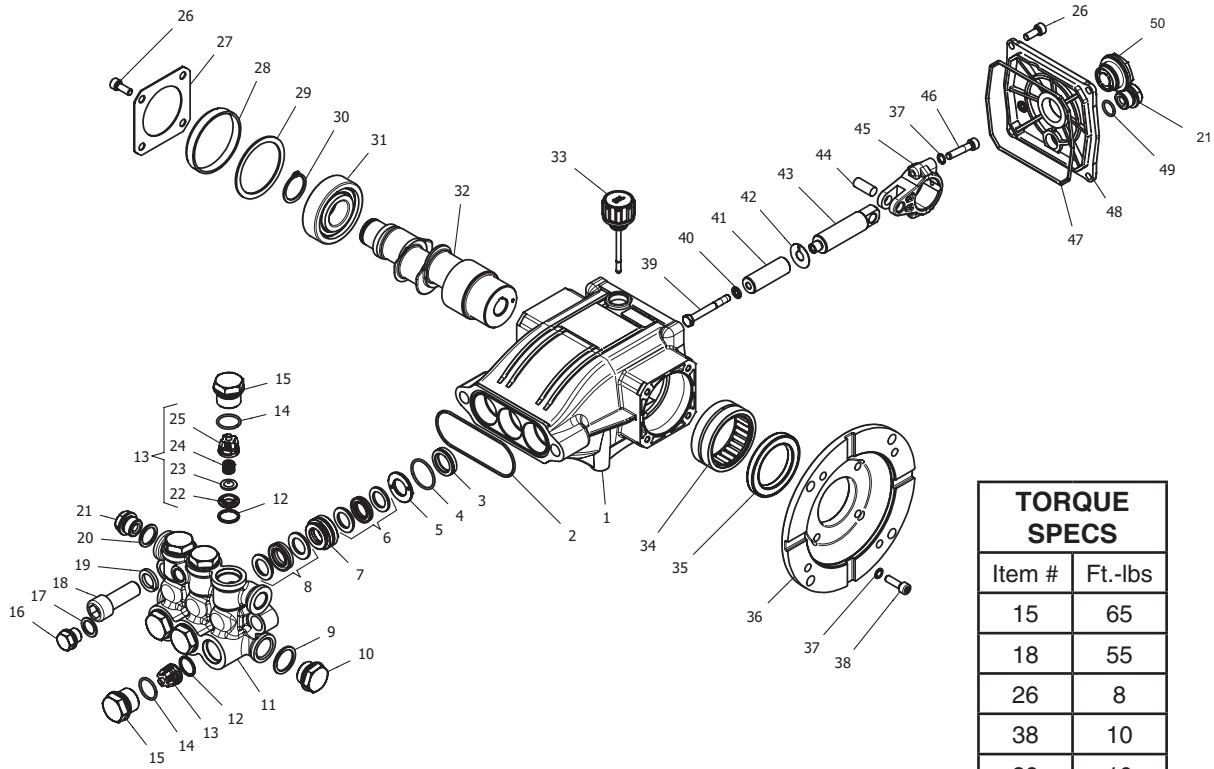

TORQUE SPECS	
Item #	Ft.-lbs
15	65
18	55
26	8
38	10
39	10
46	10

HF 2030S SERIES PUMP PARTS LIST

ITEM	PART NO.	DESCRIPTION	QTY	ITEM	PART NO.	DESCRIPTION	QTY
1	8.754-841.0	Crankcase	1	19	8.754-850.0	Washer, Lock	2
2	8.754-846.0	O-ring Ø1.78 X 72.75	1	20	9.803-198.0	Washer, Copper G3/8	1
3*	See Kits Below Plunger Oil Seal		3	21	8.707-262.0	Plug, Brass G3/8	2
4*	See Kits Below O-ring Ø1.78 X 26.7		3	22*	See Kits Below Valve Seat		6
5*	See Kits Below Washer, Pressure Ring		3	23*	See Kits Below Valve Plate		6
6*	See Kits Below U-Seal		3	24*	See Kits Below Valve Spring		6
7*	See Kits Below Pressure Ring		3	25*	See Kits Below Valve Cage		6
8*	See Kits Below U-Seal		3	26	9.802-939.0	Screw, M6 X 16	8
9	9.803-199.0	Washer, Copper G1/2	1	27	8.717-137.0	Bearing Cover	1
10	9.802-926.0	Plug, Brass G1/2	1	28	9.803-954.0	Bearing Seal	1
11	8.754-852.0	Manifold (16mm Models)	1	29	8.754-843.0	Seal Spacer, Crankshaft	1
	8.754-853.0	Manifold (14mm Models)	1	30	9.802-914.0	Snap Ring, 25 mm	1
12*	8.717-233.0	O-ring Ø1.78 X 15.6	6	31	9.803-955.0	Bearing, Ball	1
13*	See Kits Below Valve Assembly		6	32	8.754-836.0	Shaft, 5/8" Hollow	1
14*	9.803-948.0	O-ring Ø1.78 X 18.77	6	33	8.754-219.0	Oil Dipstick	1
15	9.803-949.0	Valve Plug	6	34	8.754-840.0	Bearing Needle	1
16	8.754-851.0	Plug, Brass G1/4 (16mm)	1	35	8.754-826.0	Seal, Crankshaft	1
17	8.754-845.0	Washer, Copper G1/4 (16mm Models)	1	36	8.754-844.0	Flange, Motor	1
18	8.754-854.0	Bolt, Manifold M14 X 40	2	37	9.803-210.0	Washer	10
				38	8.752-824.0	Screw, 6 mm	4

LF 2030S SERIES PUMP PARTS LIST

ITEM	PART NO.	DESCRIPTION	QTY
39*	8.754-855.0	Bolt, Plunger	3
40*	8.754-092.0	Spacer, Copper	3
41	8.754-848.0	Plunger, 16mm	3
42	9.803-962.0	Spacer, Copper	3
43	8.754-827.0	Plunger Rod	3
44	9.803-965.0	Connecting Rod Pin	3
45	9.803-966.0	Connecting Rod	3
46	8.933-020.0	Screw, Connecting Rod	6
47	8.754-847.0	O-ring Ø2.62 X 111.62	1
48	8.754-842.0	Cover, Crankcase	1
49	9.803-906.0	O-ring Ø1.78 X 14	1
50	9.803-202.0	Sight Glass, G3/4	1

REPAIR KIT NUMBER	8.754-860.0	8.754-856.0	8.754-861.0	8.754-857.0	8.754-862.0	8.754-858.0	8.754-859.0	9.803-937.0
KIT DESCRIPTION	Plunger Seals 14 mm**	Plunger Seals 16 mm**	Seal Packing 14 mm**	Seal Packing 16 mm**	Plunger 14 mm**	Plunger 16 mm**	Complete Valve	Plunger Oil Seals
ITEM NUMBERS INCLUDED	4, 6, 8	4, 6, 8	4, 5, 6, 7, 8	4, 5, 6, 7, 8	39, 40, 41, 42	39, 40, 41, 42	12, 13, 14	3

LF3530F SERIES PUMP EXPLODED VIEW

8.924-746.0 LF3530F

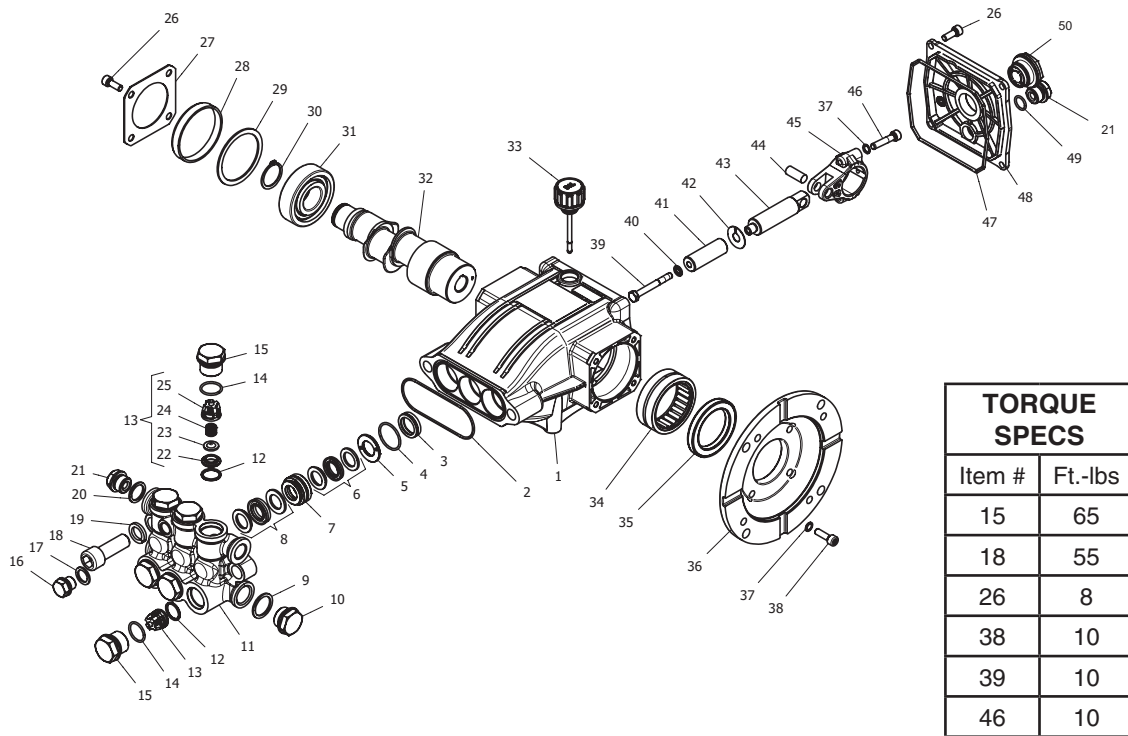

LF3530F SERIES PUMP EXPLODED VIEW PARTS LIST

ITEM	PART NO.	DESCRIPTION	QTY	ITEM	PART NO.	DESCRIPTION	QTY
1	8.754-841.0	Crankcase	1	19	8.754-850.0	Washer, Lock	2
2	8.754-846.0	O-ring Ø1.78 X 72.75	1	20	9.803-198.0	Washer, Copper G3/8	1
3*	See Kits Below Plunger Oil Seal		3	21	8.707-262.0	Plug, Brass G3/8	2
4*	See Kits Below O-ring Ø1.78 X 26.7		3	22*	See Kits Below Valve Seat		6
5*	See Kits Below Washer, Pressure Ring		3	23*	See Kits Below Valve Plate		6
6*	See Kits Below U-Seal		3	24*	See Kits Below Valve Spring		6
7*	See Kits Below Pressure Ring		3	25*	See Kits Below Valve Cage		6
8*	See Kits Below U-Seal		3	26	9.802-939.0	Screw, M6 X 16	8
9	9.803-199.0	Washer, Copper G1/2	1	27	8.717-137.0	Bearing Cover	1
10	9.802-926.0	Plug, Brass G1/2	1	28	9.803-954.0	Bearing Seal	1
11	8.754-852.0	Manifold (16mm Models)	1	29	8.754-843.0	Seal Spacer, Crankshaft	1
	8.754-853.0	Manifold (14mm Models)	1	30	9.802-914.0	Snap Ring, 25 mm	1
12*	8.717-233.0	O-ring Ø1.78 X 15.6	6	31	9.803-955.0	Bearing, Ball	1
13*	See Kits Below Valve Assembly		6	32	8.754-839.0	Shaft, 5/8" Hollow	1
14*	9.803-948.0	O-ring Ø1.78 X 18.77	6	33	8.754-219.0	Oil Dipstick	1
15	9.803-949.0	Valve Plug	6	34	8.754-840.0	Bearing Needle	1
16	8.754-851.0	Plug, Brass G1/4 (16mm)	1	35	8.754-826.0	Seal, Crankshaft	1
17	8.754-845.0	Washer, Copper G1/4 (16mm Models)	1	36	8.754-844.0	Flange, Motor	1
18	8.754-854.0	Bolt, Manifold M14 X 40	2	37	9.803-210.0	Washer	10
				38	8.752-824.0	Screw, 6 mm	4

LF3530F SERIES PUMP EXPLODED VIEW PARTS LIST

ITEM	PART NO.	DESCRIPTION	QTY
39*	8.754-855.0	Bolt, Plunger	3
40*	8.754-092.0	Spacer, Copper	3
41	8.754-849.0	Plunger, 14mm	3
42	9.803-962.0	Spacer, Copper	3
43	8.754-827.0	Plunger Rod	3
44	9.803-965.0	Connecting Rod Pin	3
45	9.803-966.0	Connecting Rod	3
46	8.933-020.0	Screw, Connecting Rod	6
47	8.754-847.0	O-ring Ø2.62 X 111.62	1
48	8.754-842.0	Cover, Crankcase	1
49	9.803-906.0	O-ring Ø1.78 X 14	1
50	9.803-202.0	Sight Glass, G3/4	1

REPAIR KIT NUMBER	8.754-860.0	8.754-861.0	8.754-862.0	8.754-859.0	9.803-937.0
KIT DESCRIPTION	Plunger Seals 14 mm	Seal Packing 14 mm	Plunger 14 mm	Complete Valve	Plunger Oil Seals
ITEM NUMBERS INCLUDED	4, 6, 8	4, 5, 6, 7, 8	39, 40, 41, 42	12, 13, 14	3
NO. OF CYLINDERS KIT WILL SERVICE	3	1	1	6	3

LF2830S SERIES PUMP EXPLODED VIEW

8.754-763.0 PUMP, LEUCO LF2830S

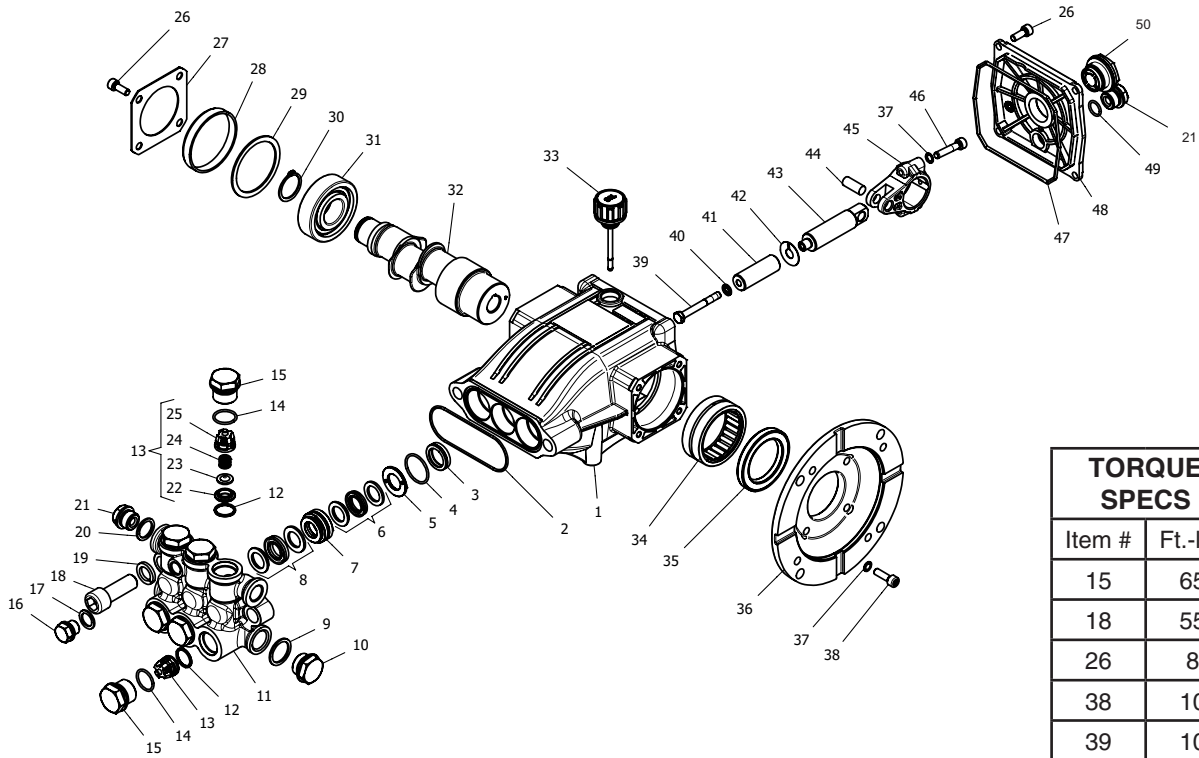

TORQUE SPECS	
Item #	Ft.-lbs
15	65
18	55
26	8
38	10
39	10
46	10

LF2830S SERIES PUMP EXPLODED VIEW PARTS LIST

ITEM	PART NO.	DESCRIPTION	QTY	ITEM	PART NO.	DESCRIPTION	QTY
1	8.754-841.0	Crankcase	1	20	9.803-198.0	Washer, Copper G3/8	1
2	8.754-846.0	O-ring Ø1.78 X 72.75	1	21	8.707-262.0	Plug, Brass G3/8	2
3*	See Kit Below	Plunger Oil Seal	3	22*	See Kits Below	Valve Seat	6
4*	See Kit Below	O-ring Ø1.78 X 26.7	3	23*	See Kits	Below Valve Plate	6
5*	See Kit Below	Washer, Pressure Ring	3	24*	See Kits	Below Valve Spring	6
6*	See Kit Below	U-Seal	3	25*	See Kits	Below Valve Cage	6
7*	See Kit Below	Pressure Ring	3	26	9.802-939.0	Screw, M6 X 16	8
8*	See Kit Below	U-Seal	3	27	8.717-137.0	Bearing Cover	1
9	9.803-199.0	Washer, Copper G1/2	1	28	9.803-954.0	Bearing Seal	1
10	9.802-926.0	Plug, Brass G1/2	1	29	8.754-843.0	Seal Spacer, Crankshaft	1
11	8.754-852.0	Manifold	1	30	9.802-914.0	Snap Ring, 25 mm	1
12*	8.717-233.0	O-ring Ø1.78 X 15.6 6	6	31	9.803-955.0	Bearing, Ball	1
13*	See Kit Below	Valve Assembly	6	32	8.754-835.0	Shaft, 5/8" Hollow 2030F	1
14*	9.803-948.0	O-ring Ø1.78 X 18.77	6		8.754-836.0	Shaft, 5/8" Hollow 2030S	1
15	9.803-949.0	Valve Plug	6		8.754-837.0	Shaft, 5/8" Hollow 2830F	1
16	8.754-851.0	Plug, Brass G1/4	1		8.754-838.0	Shaft, 5/8" Hollow 2830S	1
17	8.754-845.0	Washer, Copper G1/4	1		8.754-839.0	Shaft, 5/8" Hollow 3530F	1
18	8.754-854.0	Bolt, Manifold M14 X 40	2	33	8.754-219.0	Oil Dipstick	1
19	8.754-850.0	Washer, Lock	2	34	8.754-840.0	Bearing Needle	1
				35	8.754-826.0	Seal, Crankshaft	1

LF2830S SERIES PUMP EXPLODED VIEW PARTS LIST

ITEM	PART NO.	DESCRIPTION	QTY
36	8.754-844.0	Flange, Motor	1
37	9.803-210.0	Washer	10
38	8.752-824.0	Screw, 6 mm	4
39*	8.754-855.0	Bolt, Plunger	3
40*	8.754-092.0	Spacer, Copper	3
41	8.754-848.0	Plunger, 16mm (2030S, 2830S)	3
	8.754-849.0	Plunger, 14mm (2030F, 2830F, 3530F)	3
42	9.803-962.0	Spacer, Copper	3
43	8.754-827.0	Plunger Rod	3
44	9.803-965.0	Connecting Rod Pin	3
45	9.803-966.0	Connecting Rod	3
46	8.933-020.0	Screw, Connecting Rod	6
47	8.754-847.0	O-ring Ø2.62 X 111.62	1
48	8.754-842.0	Cover, Crankcase	1
49	9.803-906.0	O-ring Ø1.78 X 14	1
50	9.803-202.0	Sight Glass, G3/4	1

REPAIR KITS

REPAIR KIT NUMBER	8.754-860.0	8.754-856.0	8.754-861.0	8.754-857.0	8.754-862.0	8.754-858.0	8.754-859.0	9.803-937.0
KIT DESCRIPTION	Plunger Seals 14 mm	Plunger Seals 16 mm	Seal Packing 14 mm	Seal Packing 16 mm	Plunger 14 mm	Plunger 16 mm	Complete Valve	Plunger Oil Seals
ITEM NUMBERS INCLUDED	4, 6, 8	4, 6, 8	4, 5, 6, 7, 8	3, 4, 5, 6, 7	39, 40, 41, 42	39, 40, 41, 42	12, 13, 14	3
NO. OF CYLINDERS KIT WILL SERVICE	3	3	1	1	1	1	6	3

VRT3 UNLOADER EXPLODED VIEW AND PART S LIST

8.750-299.0, 8 GPM, 4500 PSI

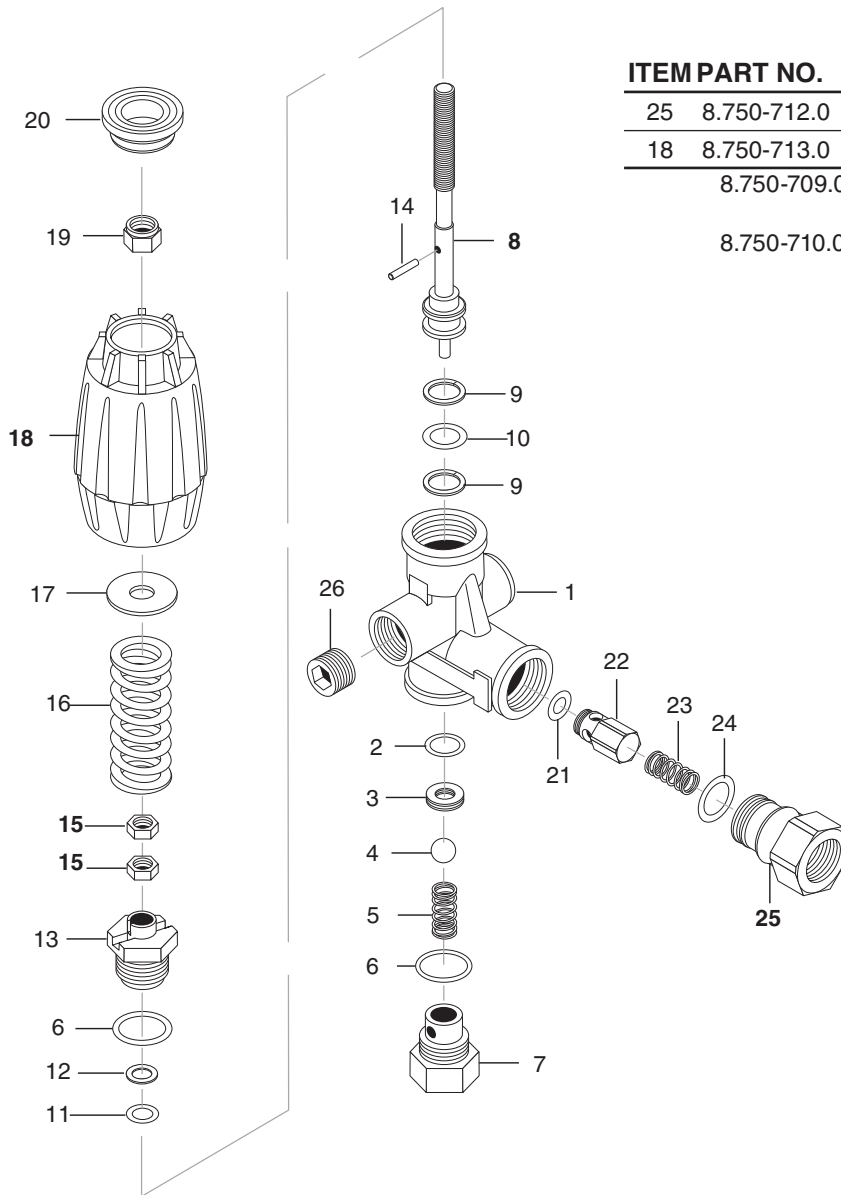

ITEM	PART NO.	DESCRIPTION	QTY
25	8.750-712.0	Outlet Fitting	1
18	8.750-713.0	Knob, Unloader	1
	8.750-709.0	Repair Kit, VRT3, 2320/3630 PSI	
	8.750-710.0	Repair Kit, VRT3, 4500 PSI (Kit Items: 1, 4, 8-12, 16, 21-22)	

Unloader Adjustment Procedures

1. Remove lock nut (Item 19).
2. Remove adjustment knob (Item 18).
3. Loosen the two (2) nuts (Item 15), move them upward on stem (Item 8) until you see 4 or more threads below the nut.
4. Re-attach adjusting knob (Item 18).
5. Start machine. Open the trigger of the spray gun. Increase pressure by turning adjustment knob (Item 18) clockwise until pressure is at the desired operating pressure.
6. Remove the adjustment knob (Item 18), tighten the lower nut (Item 15) tightly against the upper nut (Item 15). Reattach adjustment knob (Item 18) and screw down until contact is made with the nuts (Items 15). Screw down lock nut (Item 19) onto the stem (Item 8) until the threads cut into the nylon insert of the lock nut (Item 19).

*If adjustment knob (Item 18) DOES NOT make contact with upper nut (Items 15), remove adjusting knob (Item 18), re-adjust (raise) nuts (Items 15) on stem (Item 8) and re-attach adjustment knob (Item 18), then repeat step #6.

**If adjustment knob (Item 18) DOES make contact with upper nut; release the trigger of the spray gun and watch the pressure gauge for the pressure increase ("spike"). This "spike" SHOULD NOT exceed 500 psi above the operating pressure. If "spike" pressure exceeds the 500 psi limit, remove the adjusting knob (Item 18) and re-adjust (lower) the nuts (Items 15) on the stem (Item 8).

Re-attach the adjusting knob (Item 18), then repeat step #6.

WIRING DIAGRAM

1.106-124.0 HD 2.0/1000 Ed

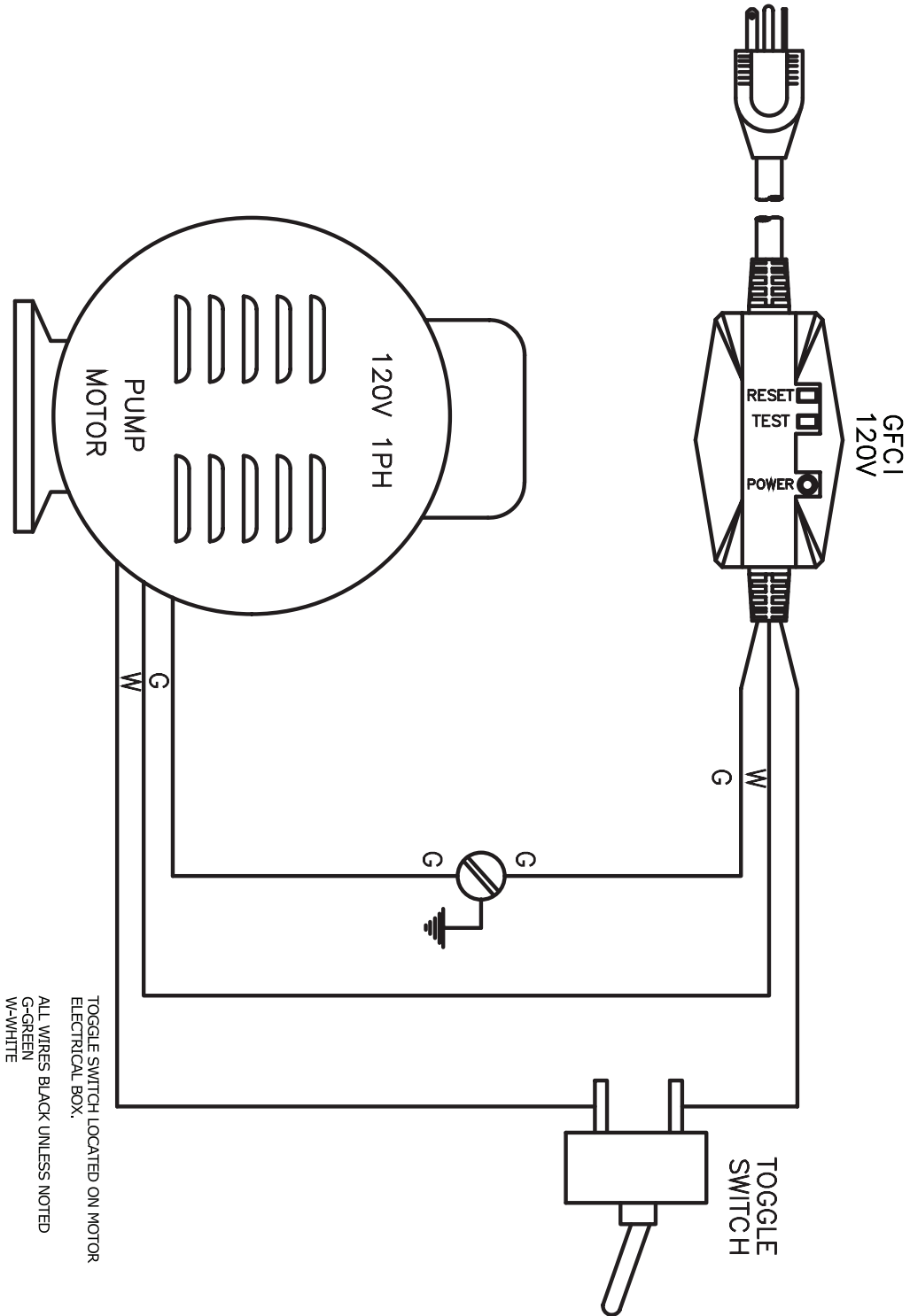

WIRING DIAGRAM

FOR 1.106-125.0 HD 1.9/1300 Ed
FOR 1.106-126.0 HD 3.0/1000 Ea

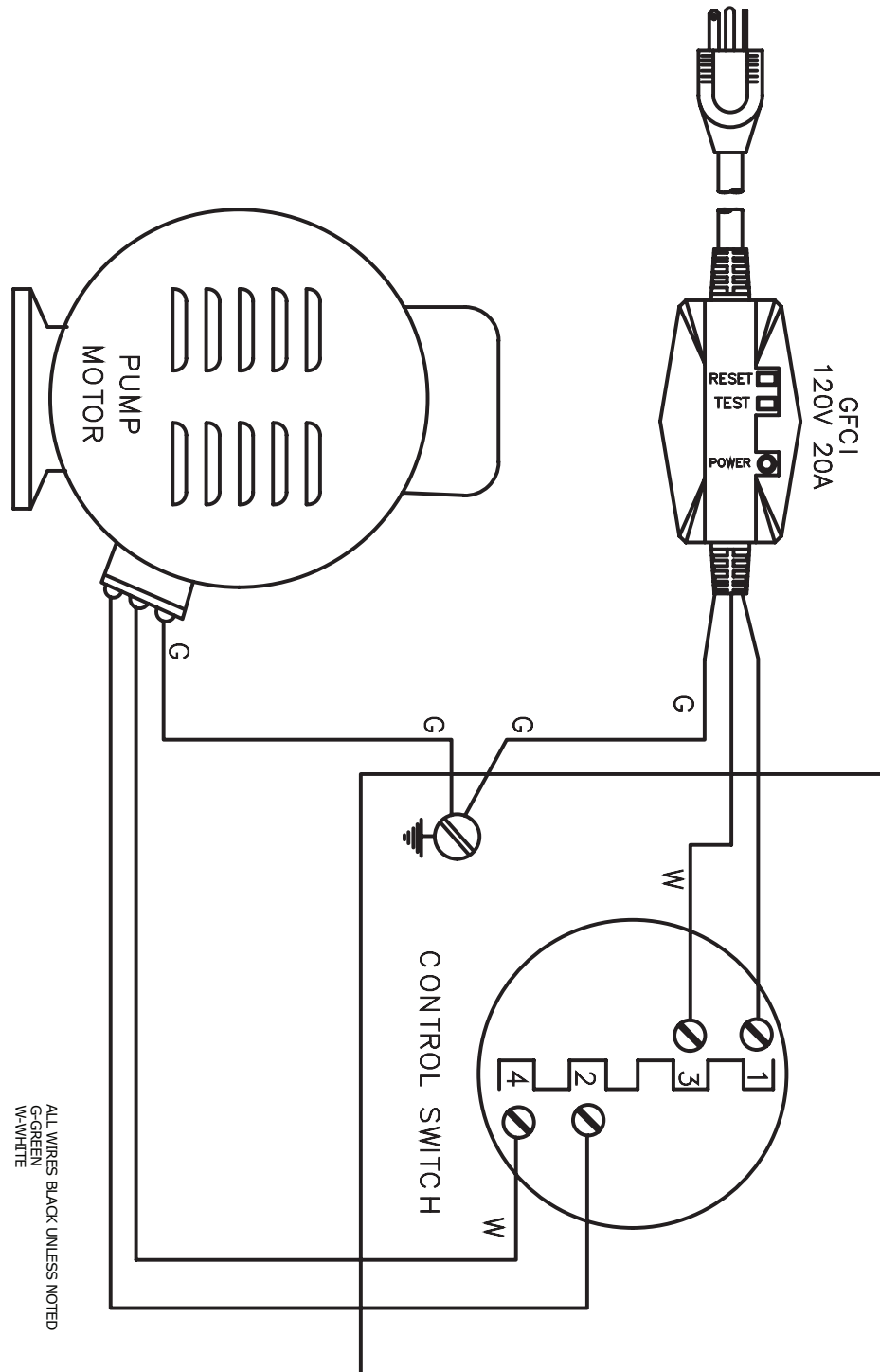

WIRING DIAGRAM

FOR 1.106-127.0 HD 3.5/2000 Ea

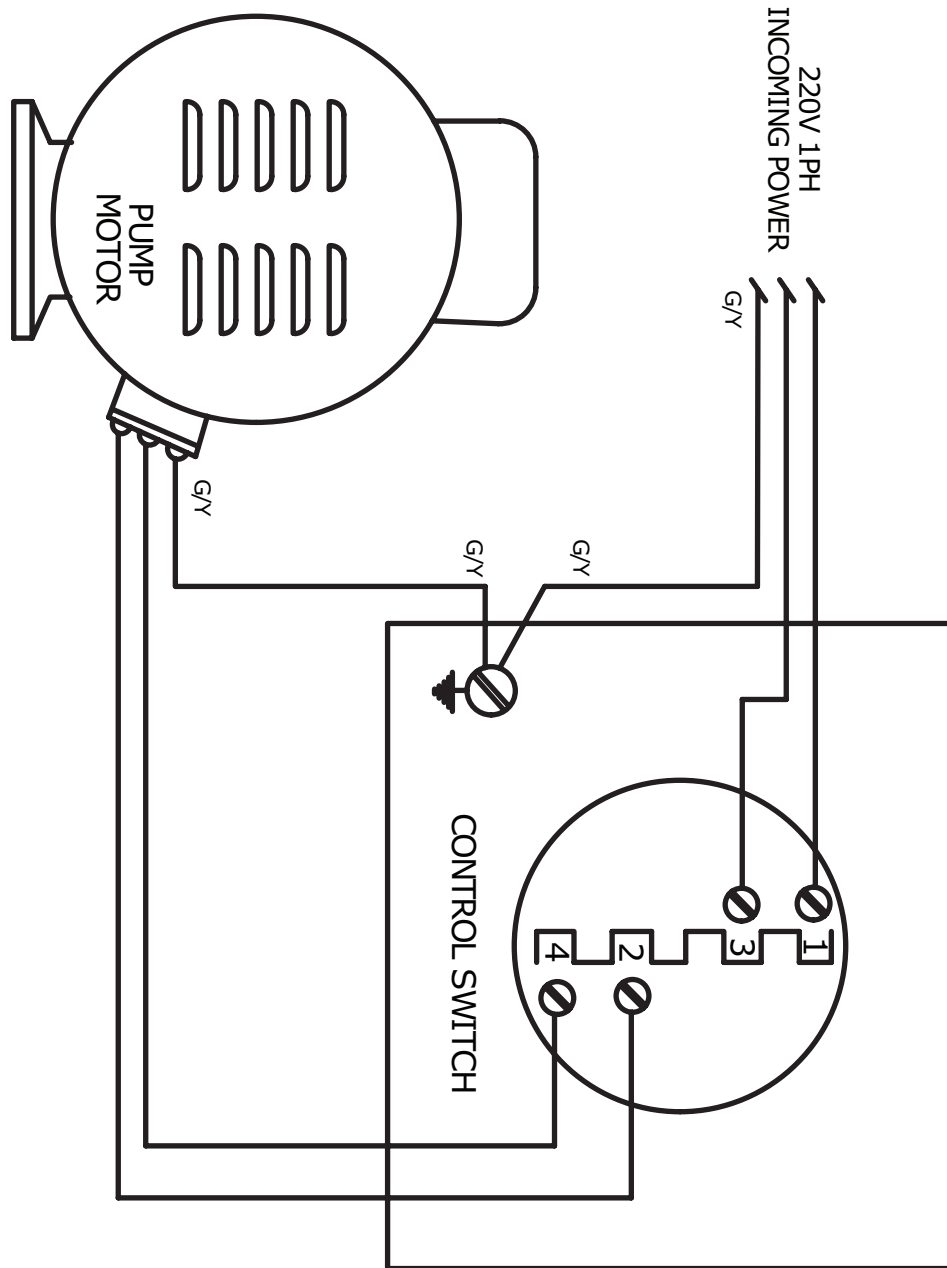

WIRE COLOR LEGEND:

ALL WIRES BLACK UNLESS NOTED
G/Y-GREEN/YELLOW

TROUBLESHOOTING

PROBLEM	POSSIBLE CAUSE	SOLUTION
PUMP RUNNING NORMALLY BUT PRESSURE LOW ON INSTALLATION	Pump sucking air	Check water supply and possibility of air seepage.
	Check valves sticking	Check and clean or replace if necessary.
	Unloader valve seat faulty	Check and replace if necessary.
	Nozzle incorrectly sized	Check and replace if necessary.
	Worn piston packing	Check and replace if necessary.
FLUCTUATING PRESSURE	Valves worn	Check and replace if necessary.
	Blockage in valve	Check and replace if necessary.
	Pump sucking air	Check water supply connections.
	Worn piston packing	Check and replace if necessary.
	Insufficient water	Check filter and hose for breakage.
PRESSURE LOW AFTER PERIOD OF NORMAL USE	Nozzle worn	Check and replace if necessary.
	Suction or delivery valves worn	Check and replace if necessary.
	Suction or delivery lines blocked	Check and clean if necessary.
	Unloader valve seat worn	Check and replace if necessary.
	Worn piston packing	Check and replace if necessary.
	Water temperature excessive	Reduce to below 160° F.
PUMP NOISY	Air in suction line	Check water supply and connections on suction line.
	Broken or weak suction or delivery valve spring	Check and replace if necessary.
	Foreign matter in valves	Check and clean if necessary.
	Worn bearings	Check and replace if necessary.
	Excessive temperature of water	Reduce to below 160° F.
PRESENCE OF WATER IN PUMP OIL	Oil seal worn	Check and replace if necessary.
	High humidity in air	Check and replace if necessary.
	Piston packing worn	Check and replace if necessary.
WATER DRIPPING FROM UNDER PUMP	Piston packing worn	Check and replace if necessary.
	O-ring plunger retainer worn	Check and replace if necessary.
WATER DRIPPING FROM PUMP PROTECTOR	Water supply pressure too high (over 90 PSI)	Lower water supply pressure using a regulator.
	Spray gun is in the off position for over 5 minutes	Turn machine off if not in use for over 1-2 minutes.
OIL DRIPPING	Oil seal worn	Check and replace if necessary.
EXCESSIVE VIBRATION IN HIGH PRESSURE HOSE	Irregular functioning of the pump valves	Check and replace if necessary.
MOTOR DOES NOT START WHEN SWITCHED ON	Plug not well connected or lack of power supply	Check plug, cable and switch.
WHEN SWITCHING ON THE MACHINE, MOTOR HUMS BUT DOES NOT RUN	Main voltage is insufficient, lower than the minimum required	Check to make sure main power supply is adequate.
	The pump is stuck or frozen	Check by turning the motor manually.
MOTOR STOPS	Tripped thermal overload due to over-heating	Check that main voltage corresponds to the specifications. Wait a few minutes before turning on the machine again by resetting the GFCI cord.

KNA, Inc.4555 Airport Way Denver, CO 80239

Form #9.801-811.0 • Rev. 01/20 Printed in U.S.A. or Mexico