

Models

P55W/P56W/P56W-HK/P56HT

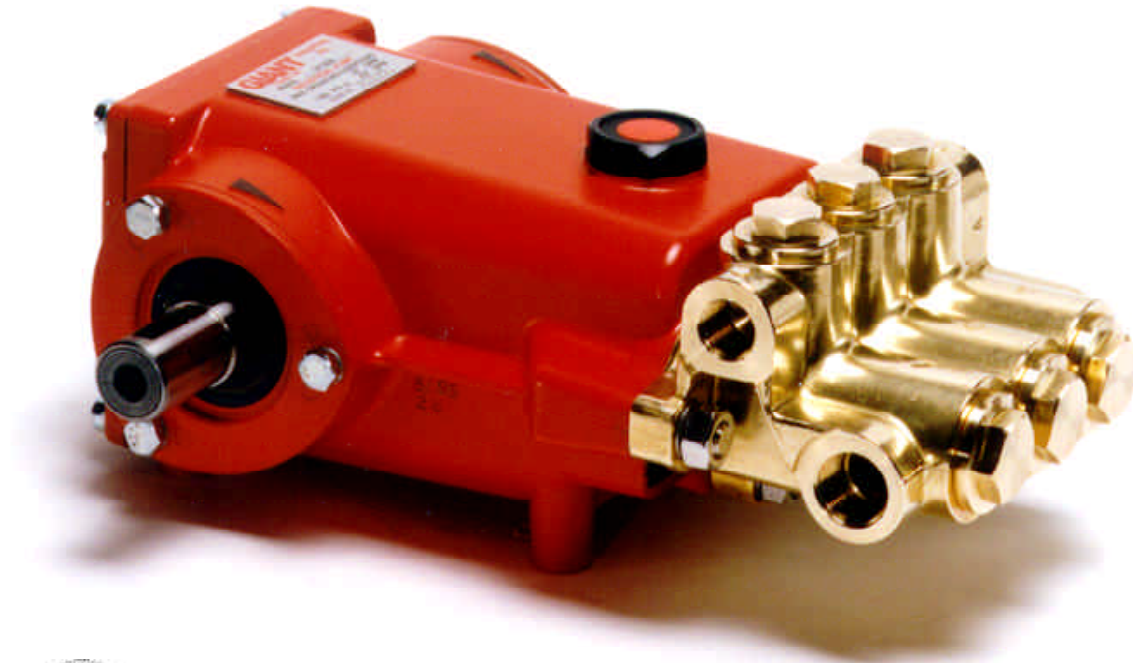

Contents:

Installation Instructions:	page 2
Pump Specifications:	pages 3-5
Exploded View:	page 6
Parts List:	page 7
Kits:	page 8
Trouble Shooting:	page 9
Repair Instructions:	page 10-13
Pump Mounting Selection Guide:	page 14
Recommended Spare Parts List:	page 14
Torque Specifications:	page 14
Dimensions:	page 15
Warranty Information:	back page

INSTALLATION INSTRUCTIONS

Installation of the Giant Industries, Inc., pump is not a complicated procedure, but there are some basic steps common to all pumps. The following information is to be considered as a general outline for installation. If you have unique requirements, please contact Giant Industries, Inc. or your local distributor for assistance.

1. The pump should be installed flat on a base to a maximum of a 15 degree angle of inclination to ensure optimum lubrication.
2. The inlet to the pump should be sized for the flow rate of the pump with no unnecessary restrictions that can cause cavitation. Teflon tape should be used to seal all joints. If pumps are to be operated at temperatures in excess of 160°F (P56W), 190°F (P56W-HK) or 220° F (P56HT), it is important to insure a positive head to the pump to prevent cavitation.
3. The discharge plumbing from the pump should be properly sized to the flow rate to prevent line pressure loss to the work area. It is essential to provide a safety bypass valve between the pump and the work area to protect the pump from pressure spikes in the event of a blockage or the use of a shut-off gun.
4. Use of a dampener is necessary to minimize pulsation at drive elements, plumbing, connections, and other system areas. The use of a dampener with Giant Industries, Inc. pumps is optional, although

recommended by Giant Industries, Inc. to further reduce system pulsation. Dampeners can also reduce the severity of pressure spikes that occur in systems using a shut-off gun. A dampener must be positioned downstream from the unloader.

5. Crankshaft rotation on Giant Industries, Inc. pumps should be made in the direction designated by the arrows on the pump crankcase. Reverse rotation may be safely achieved by following a few guidelines available upon request from Giant Industries, Inc. Required horsepower for system operation can be obtained from the charts on pages 3-4.
6. Before beginning operation of your pumping system, remember: Check that the crankcase and seal areas have been properly lubricated per recommended schedules. Do not run the pump dry for extended periods of time. Cavitation will result in severe damage. Always remember to check that all plumbing valves are open and that pumped media can flow freely to the inlet of the pump.

Finally, remember that high pressure

operation in a pump system has many advantages. But, if it is used carelessly and without regard to its potential hazard, it can cause serious injury.

IMPORTANT OPERATING CONDITIONS

Failure to comply with any of these conditions invalidates the warranty

1. Prior to initial operation, add oil to crankcase so that the oil level is between the two lines on the oil dipstick. **DO NOT OVERFILL. Giant Recommended Oil.** Crankcase oil should be changed after the first 50 hours of operation, then at regular intervals of 500 hours or less depending on operating conditions.

2. Pump operation must not exceed rated pressure, volume, or RPM. A pressure relief device must be installed in the discharge of the system.

3. Acids, alkalines, or abrasive fluids cannot be pumped unless approval in writing is obtained before operation from Giant Industries, Inc.

4. Run the pump dry approximately 10 seconds to drain the water before exposure to freezing temperatures.

NOTE: Contact Giant Industries for Service School Information. Phone: (419)-531-4600.

Specifications

Model P55W

Ratings (Continuous)	4.9 GPM (18.5 lm) @ 2320 PSI (160 bar) @ 1420 RPM
Ratings (Intermittent)	6.0 GPM (22.7 lm) @ 1000 PSI (69 bar) @ 1750 RPM
Inlet Pressure	Up to 90 PSI
Plunger Diameter	18mm
Stroke	18.1mm
Crankcase Oil Capacity	14 fl.oz. (414 ml)
Temperature of Pumped Fluids	Up to 160 °F (71 °C)
Inlet Ports	(2) 1/2" BSPP
Discharge Ports	(2) 3/8" BSPP
Crankshaft Mounting	Either
Shaft Rotation	Top of Pulley Towards Fluid End
Weight	18 lbs. (8.16 kg)
Crankshaft Diameter	24mm
Volumetric Efficiency @ 1420 RPM	0.94
Mechanical Efficiency @ 1420 RPM	0.86

Consult the factory for special requirements that must be met if the pump is to operate beyond one or more of the limits specified above.

PULLEY INFORMATION

Pulley selection and pump speed are based on a 1725 RPM motor and "B" section belts. When selecting desired GPM, allow for a ±5% tolerance on pumps output due to variations in pulleys, belts and motors among manufacturers.

1. Select GPM required, then select appropriate motor and pump pulley from the same line.
2. The desired pressure is achieved by selecting the correct nozzle size that corresponds with the pump GPM.

HORSEPOWER INFORMATION

Horsepower ratings shown are the power requirements for the pump. Gas engine power outputs must be approximately twice the pump power requirements shown above.

We recommend that a 1.1 service factor be specified when selecting an electric motor as the power source. To compute specific pump horsepower requirements, use the following formula:

$$\frac{\text{GPM} \times \text{PSI}}{1460} = \text{hp}$$

P55W PULLEY SELECTION & HORSEPOWER REQUIREMENTS							
PUMP PULLEY	MOTOR PULLEY	RPM	GPM	500 PSI	1000 PSI	2000 PSI	2320 PSI
7.75"	4.00"	851	2.9	1.0	2.0	4.0	4.6
7.75"	4.50"	967	3.3	1.1	2.3	4.5	5.2
7.75"	5.00"	1084	3.7	1.3	2.5	5.1	5.9
7.75"	5.50"	1201	4.1	1.4	2.8	5.6	6.5
7.75"	6.00"	1317	4.5	1.5	3.1	6.2	7.2
7.75"	6.45"	1420	4.9	1.7	3.4	6.7	7.8
7.75"	7.75"	1750	6.0	2.1	4.1		

Specifications

Models P56W / P56W-HK

Ratings (Continuous)	6.1 GPM (23 lm) @ 1900 PSI (131 bar) @ 1420 RPM
Ratings (Intermittent)	6.0 GPM (23 lm) @ 2200 PSI (152 bar) @ 1750 RPM
Ratings (Intermittent)	7.5 GPM (28 lm) @ 1000 PSI (69 bar) @ 1750 RPM
Inlet Pressure	Up to 90 PSI
Plunger Diameter	20mm
Stroke	18.1mm
Crankcase Oil Capacity	14 fl.oz. (414 ml)
Temperature of Pumped Fluids	Up to 160°F (71 °C)(P56W)
.....	Up to 190° F (88 °C)(P56W-HK)
Inlet Ports	(2) 1/2" BSPP
Discharge Ports	(2) 3/8" BSPP
Crankshaft Mounting	Either
Shaft Rotation	Top of Pulley Towards Fluid End
Weight	18 lbs. (8.16 kg)
Crankshaft Diameter	24mm
Volumetric Efficiency @ 1420 RPM	0.94
Mechanical Efficiency @ 1420 RPM	0.86

Consult the factory for special requirements that must be met if the pump is to operate beyond one or more of the limits specified above.

PULLEY INFORMATION

Pulley selection and pump speed are based on a 1725 RPM motor and "B" section belts. When selecting desired GPM, allow for a ±5% tolerance on pumps output due to variations in pulleys, belts and motors among manufacturers.

1. Select GPM required, then select appropriate motor and pump pulley from the same line.
2. The desired pressure is achieved by selecting the correct nozzle size that corresponds with the pump GPM.

HORSEPOWER INFORMATION

Horsepower ratings shown are the power requirements for the pump. Gas engine power outputs must be approximately twice the pump power requirements shown above.

We recommend that a 1.1 service factor be specified when selecting an electric motor as the power source. To compute specific pump horsepower requirements, use the following formula:

$$\frac{\text{GPM} \times \text{PSI}}{1460} = \text{hp}$$

P56W/P56W-HK PULLEY SELECTION & HORSEPOWER REQUIREMENTS								
PUMP PULLEY	MOTOR PULLEY	RPM	GPM	500 PSI	1000 PSI	1500 PSI	1900 PSI	2200* PSI
7.75"	4.00"	851	3.7	1.3	2.5	3.8	4.8	5.6
7.75"	4.50"	967	4.2	1.4	2.9	4.3	5.5	6.3
7.75"	5.00"	1084	4.7	1.6	3.2	4.8	6.1	7.1
7.75"	5.50"	1201	5.2	1.8	3.6	5.3	6.8	7.8
7.75"	6.00"	1317	5.7	2.0	3.9	5.9	7.4	8.6
7.75"	6.45"	1420	6.1	2.1	4.2	6.3	7.9	9.2
7.75"	7.75	1750*	7.5	2.6	5.1			

*Intermittent Duty Only

Specifications Models P56HT

750 RPM @ 220° F (104 °C)

Ratings 193 GPH (730 lh) (3.2 GPM)

900 RPM @ 195° F (91 °C)

Ratings 233 GPH (882 lh) (3.9 GPM)

Discharge Pressure 900 PSI

Plunger Diameter 20mm

Stroke 18.1 mm

Crankcase Oil Capacity 14 fl.oz. (414 ml)

Temperature of Pumped Fluids Up to 220° F (104 °c)

Inlet Ports (2) 1/2" BSPP

Discharge Ports (2) 3/8" BSPP

Crankshaft Mounting Top of Pulley Towards Fluid End

Weight 18 lbs. (8.16 kg)

Crankshaft Diameter 3/4"

Consult the factory for special requirements that must be met if the pump is to operate beyond one or more of the limits specified above.

PULLEY INFORMATION

Pulley selection and pump speed are based on a 1725 RPM motor and "B" section belts. When selecting desired GPM, allow for a ±5% tolerance on pumps output due to variations in pulleys, belts and motors among manufacturers.

1. Select GPM required, then select appropriate motor and pump pulley from the same line.
2. The desired pressure is achieved by selecting the correct nozzle size that corresponds with the pump GPM.

HORSEPOWER INFORMATION

Horsepower ratings shown are the power requirements for the pump. Gas engine power outputs must be approximately twice the pump power requirements shown above.

We recommend that a 1.1 service factor be specified when selecting an electric motor as the power source. To compute specific pump horsepower requirements, use the following formula:

$$\frac{\text{GPH} \times \text{PSI}}{87000} = \text{hp} = \frac{\text{GPM} \times \text{PSI}}{1450}$$

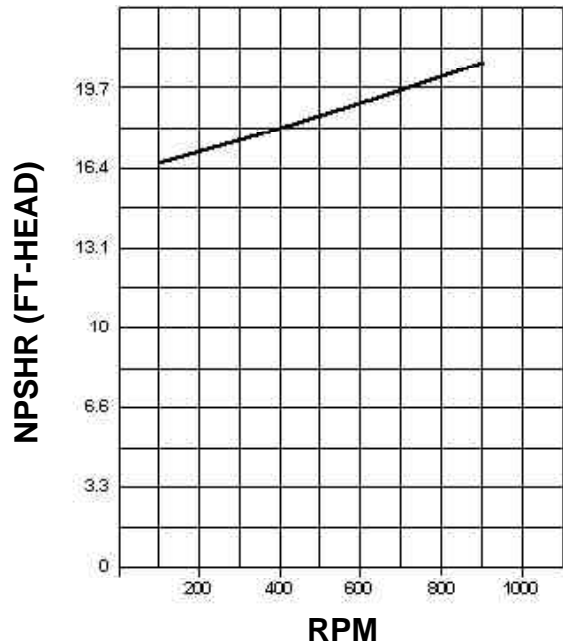

P56HT PULLEY SELECTION AND HORSEPOWER REQUIREMENTS						
PUMP PULLEY	MOTOR PULLEY	GPM	RPM	500 PSI	700 PSI	900 PSI
7.75	3.65"	1.7	400	0.6	0.8	1.1
7.75	4.50"	2.2	500	0.8	1.1	1.4
7.75	5.25"	2.6	600	0.9	1.3	1.6
7.75	7.00"	3.5	800	1.2	1.7	2.2
7.75	7.75"	3.9	900	1.3	1.9	2.4

Exploded View - P55W / P56W / P56W-HK / P56HT

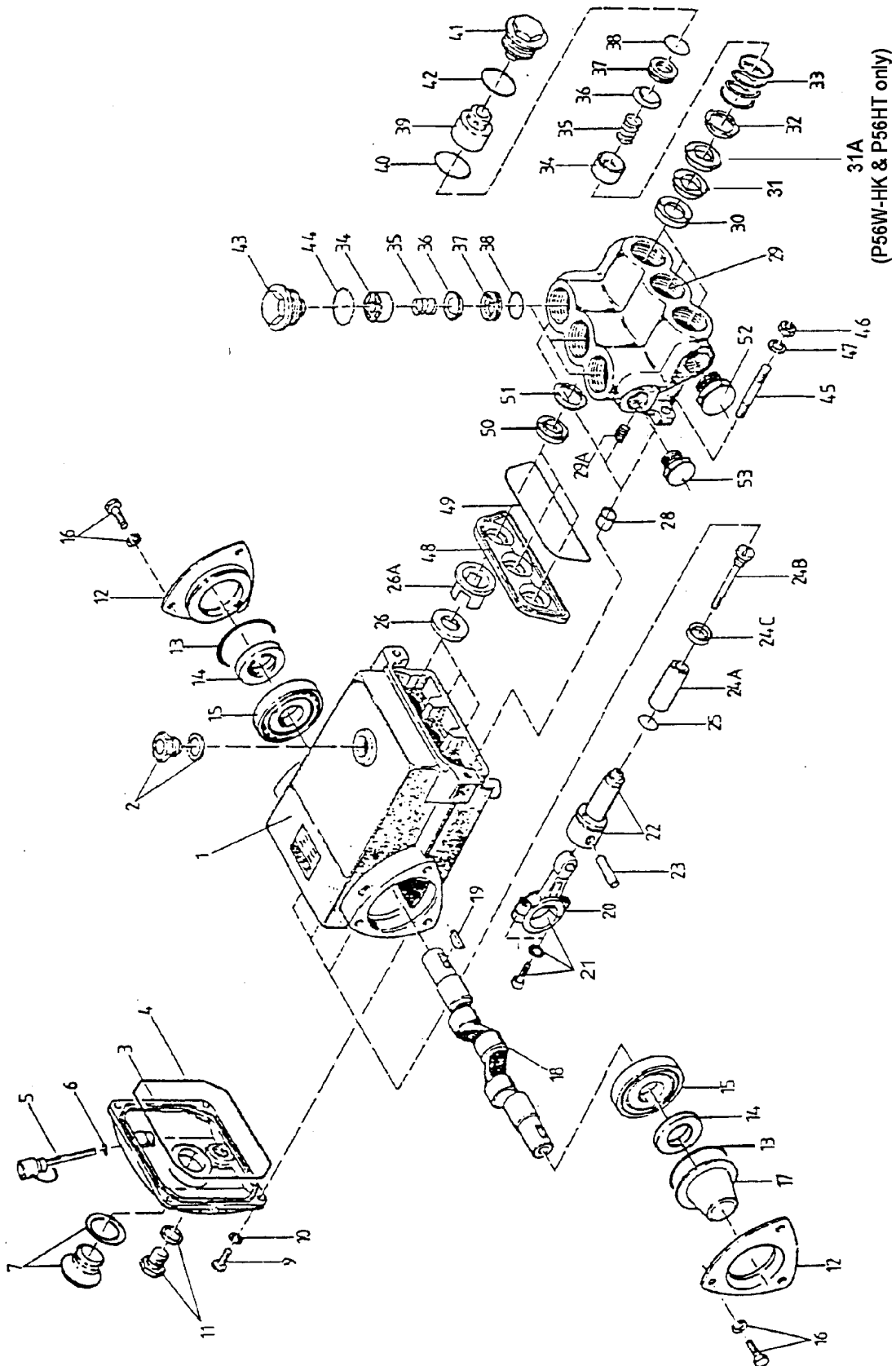

P55W / P56W / P56W-HK / P56HT PARTS LIST

<u>ITEM</u>	<u>PART</u>	<u>DESCRIPTION</u>	<u>QTY.</u>	<u>ITEM</u>	<u>PART</u>	<u>DESCRIPTION</u>	<u>QTY.</u>
1	07180	Crankcase	1	29	07369	Manifold Head	1
2	07181	Oil Filler Cap with Gasket	1	30	07010	Pressure Ring, P55W	3
2A	07182	Gasket, Oil Filler Cap	1	30	07221	Pressure Ring, P56W	3
3	07183	Cover, Crankcase	1	31	07011	V-Sleeve, P55W	3
4	07184	O-Ring, Crankcase Cover	1	31	06076	V-Sleeve, P56W & P56W-HK	3
5	07185	Oil Dip Stick Assembly	1	31	06537	V-Sleeve, P56HT	3
6	01009	O-Ring, Dip Stick	1	31A	06537	High Pressure Seal (P56W-HK)	3
7	07186	Oil Sight Glass	1	31A	13355	High Pressure Seal (P56HT)	3
8	07187	Gasket, Oil Sight Glass	1	32	07012	Support Ring, P55W	3
9	07188	Screw, Crankcase Cover	4	32	07209	Support Ring, P56W, P56W-HK	3
10	07223	Spring Washer (except P56HT)	4	33	07210	Pressure Spring	3
10	07223-0100	Spring Washer, (P56-HT only)	4	34	07325	Retainer, Spring (except P56HT)	6
11	07190	Oil Drain Plug Assembly	2	34	06018-0100	Retainer, Spring (P56HT only)	6
11A	13262	Gasket, Oil Drain Plug	2	35	06017-0100	Valve Spring	6
12	07192	Bearing Cover	2	36	06016	Valve Plate	6
12	13402	Bearing Cover (P56HT only)	2	37	06014	Valve Seat	6
13	07193	O-Ring, Bearing Cover	2	38	06015	O-Ring, Valve Seat	6
14	01166	Radial Shaft Seal	2	39	07211	Adapter, Inlet Valve (except P56HT)	3
15	01086	Ball Bearing	2	39	13356	Adapter Inlet Valve (P56HT only)	3
16	07196	Screw, Bearing Cover (except P56HT)	6	40	07212	O-Ring, Adapter	3
16	07114	Screw, Bearing Cover (P56HT only)	6	41	07213	Plug, Manifold (Inlet Only)	3
17	07197	Shaft Protector (except P56HT)	1	42	07214	O-Ring, Manifold Plug (Inlet)	3
17	13329	Shaft Protector (P56HT only)	1	43	07034	Plug, and O-ring (Discharge)	3
18	13330	Crankshaft (24mm)	1	44	07035	O-Ring, Manifold Plug (Discharge)	3
18	13354	Crankshaft (22mm)	1	45	07215	Stud, Manifold	4
19	13331	Straight Key, 8mm	1	46	08040	Hex Nut, Manifold Stud	4
19	01024	Woodruff Key (P56HT)	1	47	08041	Spring Washer, Stud	4
20 ¹	07199	Connecting Rod Assembly	3	48	07017	Housing, Rear V-Sleeve, P55W	1
21 ¹	01027	Conn. Rod Screw w/ Washer	6	48	07036	Housing, Rear V-Sleeve, P56W	1
22	07201	Plunger Base w/ S.S. Crosshead	3	49	07218	O-Ring, Rear V-Sleeve Housing	1
23	01031	Crosshead Pin	3	50	06241	Grooved Seal Ring, Brown, P55W	3
24A	07021	Ceramic Plunger 18mm, P55W	3	50	08358	Grooved Seal Ring, Black, P56W	3
24A	06066	Ceramic Plunger, 20mm, P56W (HK)	3	51	06242	Support Ring, white, P56W	3
24B	08456	Tension Screw	3	51	06240	Support Ring, white, P56W	3
24C	07676	Copper Gasket	3	52	07109	Plug, 1/2" BSP	1
25	06648	Flinger	3	52	07110	Gasket, 1/2" (except P56HT)	1
26	07206	Crankcase Oil Seal	3	53	13338	Plug, 3/8" BSP	1
26A	07764	Spacer Sleeve	3	53A	08486	Copper Crush Washer, 3/8" BSP (except P56HT)	1
28	07207	Shim, Manifold Stud	2				

¹ Item #20 comes with item #21.

² For weep pumps manufactured prior to 7/00
consult earlier manuals (1/98 and before) for the
correct parts in your pumps.

P55W / P56W / P56W-HK / P56HT REPAIR KITS

Plunger Packing Kit, P55W, #09088

<u>Item</u>	<u>Part #</u>	<u>Description</u>	<u>Qty.</u>
31	07011	V-Sleeve	3

Plunger Packing Kit, P56W, #09037

<u>Item</u>	<u>Part #</u>	<u>Description</u>	<u>Qty.</u>
31	06076	V-Sleeve	3

Plunger Packing Kit w/ Weep Seals, P55W, #09089

<u>Item</u>	<u>Part #</u>	<u>Description</u>	<u>Qty.</u>
31	07011	V-Sleeve, Front	3
50	06241	Rear V-Sleeve	3
51	06242	Support Ring	3

Plunger Packing Kit w/ Weep Seals, P56W, #09061

<u>Item</u>	<u>Part #</u>	<u>Description</u>	<u>Qty.</u>
31	06076	V-Sleeve, Front	3
50	08358	Rear V-Sleeve	3
51	06240	Support Ring	3

Plunger Packing Kit P56W-HK, #09528

<u>Item</u>	<u>Part#</u>	<u>Description</u>	<u>Qty.</u>
31	06076	V-Sleeve	3
31A	06537	High Temperature Seals	3
50	08358	Rear V-Sleeve	3
51	06240	Support Ring	3

Plunger Packing Kit, P56HT, #09457

<u>Item</u>	<u>Part #</u>	<u>Description</u>	<u>Qty.</u>
31	06537	V-Sleeve	3
31A	13358	High Pressure Seal	3
40	07212	O-Ring Adaptor	3
42	07214	O-Ring Manifold Plug (Inlet)	3
44	07035	O-Ring Manifold Plug (Discharge)	3
49	07218	O-Ring	1
50	08358	Grooved Seal Ring	3
51	06240	Support Ring	3

Ceramic Plunger Kit P55W, #9539

<u>Item</u>	<u>Part #</u>	<u>Description</u>	<u>Qty.</u>
24A	07021	Ceramic Plunger, 18mm	3
24B	08456	Tension Screw	3
24C	07676	Copper Gasket	3
25	06648	Flinger	3

Ceramic Plunger Kit P56W & P56W-HK, #9538

<u>Item</u>	<u>Part #</u>	<u>Description</u>	<u>Qty.</u>
24A	06066	Ceramic Plunger, 20mm	3
24B	08456	Tension Screw	3
24C	07676	Copper Gasket	3
25	06648	Flinger	3

Valve Assembly Kit, P55W/P56W/P56W-HK, #09041

<u>Item</u>	<u>Part #</u>	<u>Description</u>	<u>Qty.</u>
34	07325	Retainer, Valve Spring	3
35	06017-0100	Valve Spring	3
36	06016	Valve Plate	3
37	06014	Valve Seat	3
38	06015	O-Ring, Valve Seat	3
40	07212	O-Ring, Adapter (Inlet Only)	3
42	07214	O-Ring, Inlet Plug	3
44	07035	O-Ring, Discharge Plug	3

Valve Assembly Kit, P56HT, #09458

<u>Item</u>	<u>Part #</u>	<u>Description</u>	<u>Qty.</u>
34	06018-0100	Spring Disc, S.S.	6
35	06017-0100	Valve Spring, S.S.	6
36	06016	Valve Plate	6
37	06014	Valve Seat	6
38	06015	O-Ring	6

P55W / P56W / P56W-HK PUMP SYSTEM MALFUNCTIONS

<u>MALFUNCTION</u>	<u>CAUSE</u>	<u>REMEDY</u>
The Pressure and/ or the Delivery Drops	Worn packing seals Broken valve spring Belt slippage Worn or Damaged nozzle Fouled discharge valve Fouled inlet strainer Worn or Damaged hose Worn or Plugged relief valve on pump Cavitation pump for restrictions Unloader	Replace packing seals Replace spring Tighten or Replace belt Replace nozzle Clean valve assembly Clean strainer Repair/Replace hose Clean, Reset, and Replace worn parts Check suction lines on inlet of Check for proper operation
Water in crankcase	High humidity Worn seals	Reduce oil change interval Replace seals
Noisy Operation	Worn bearings oil with Cavitation	Replace bearings, Refill crankcase recommended lubricant Check inlet lines for restrictions and/or proper sizing
Rough/Pulsating Operation with Pressure Drop	Worn packing Inlet restriction Accumulator pressure Unloader Cavitation	Replace packing Check system for stoppage, air leaks, correctly sized inlet plumbing to pump Recharge/Replace accumulator Check for proper operation Check inlet lines for restrictions and/or proper size
Pump Pressure as Rated, Pressure Drop at gun	Restricted discharge plumbing	Re-size discharge plumbing to flow rate of pump
Excessive Leakage	Worn plungers Worn packing/seals Excessive vacuum Cracked plungers Inlet pressure too high	Replace plungers Adjust or Replace packing seals Reduce suction vacuum Replace plungers Reduce inlet pressure
High Crankcase Temperature	Wrong Grade of oil Improper amount of oil in crankcase	Giant oil is recommended Adjust oil level to proper amount

P55W / P56W / P56W-HK REPAIR INSTRUCTIONS

NOTE: Always take time to lubricate all metal and nonmetal parts with a light film of oil before reassembly. This step will ensure proper fit, at the same time protecting the pump nonmetal parts (i.e., the elastomers) from cutting and scoring.



1. With a 22mm socket, remove the three discharge (43) and three inlet (41) manifold plugs. Check o-ring (44) for wear and replace as necessary.



2. Remove the discharge spring retainer (34), valve spring (35), and valve plate (36).



3. Use a small slide hammer to remove valve seats (37) from manifold (29). Inspect valve plates (36) and valve seats (37) for wear. If excessive pitting is seen, replace the worn parts. Check valve seat o-ring (38) for wear and replace as necessary. Tighten manifold plugs (41 and 43) to 50 ft.-lbs.



4. Drain the oil from the pump. Turn the pump over to remove the four manifold stud nuts (46) with a 17mm wrench.



5. Tap the back of the manifold (29) with a rubber mallet to dislodge, and slide off the pump.



6. From the front inlet valve ports, remove the inlet valve assembly (34-40) and pressure springs (33).



7. Turn the manifold (29) over. Using a 15mm socket, tap out the v-sleeves. Insert v-sleeve (31) high temperature seals (31A for P56W-HK & P56HT pumps), support rings (32), and pressure rings (30) through back of manifold.

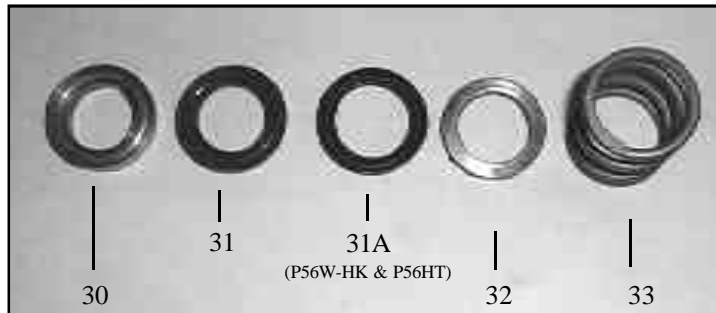

8. Inspect and clean the manifold and pressure ring. Reinstall the pressure ring (30) with the grooved side pointed towards the front. Insert v-sleeve (31) high temperature seals (31A for P56W-HK & P56HT pumps), support ring (32), and pressure spring (33) into the manifold (29).

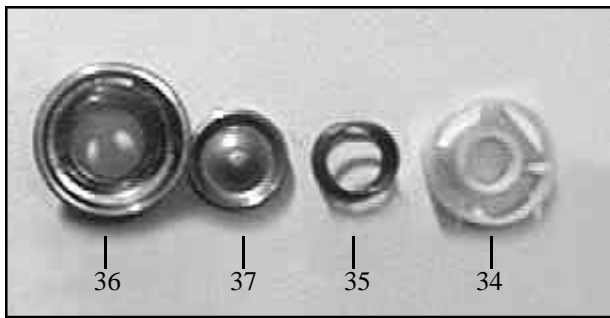

9. If pitted or worn, replace inlet valve seats (36), valve plates (37), springs (35) and spring retainers (34). Re-insert items 34-38 into valve adapter (39). Install valve assembly (34-40) into manifold (29). Reinstall manifold plugs (43) and torque plugs to 50 ft.-lbs.

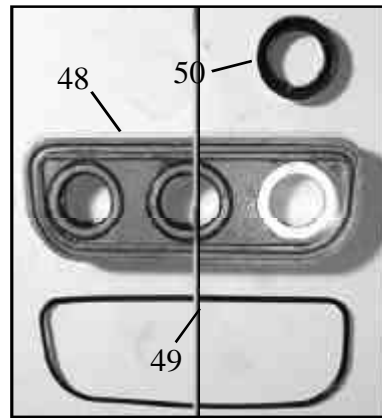

10. The rear v-sleeve housing (48) may be removed by prying evenly outward with a flat screwdriver. After slipping housing over ceramic plunger (24A), inspect seals (50) and o-ring (49) and replace as necessary. If the crankcase is to be disassembled, the housing should not be replaced until later.



11. Inspect ceramic plunger (24A) tips for wear. If necessary, replacement of the ceramic plungers may be accomplished by removing the plunger bolt assemblies (24B and 24C) with a 13mm wrench. Ceramic plungers should now slide off the stainless steel plunger base (22). Excessive resistance to plunger removal may be overcome by heating the stainless steel plunger base. This will melt any excess loc-tite beneath the ceramic plunger allowing easy removal.

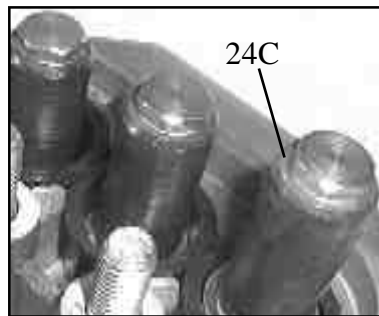

12. Replace copper ring (24C) onto plunger bolt (24B). Slide plunger bolt assembly into ceramic plunger (24A). Apply a light film of loc-tite to plunger bolt threads and place plunger assembly onto stainless steel plunger base (22) and tighten to 105 in.-lbs.

13. To replace plunger oil seals (26), proceed to "Gear End Disassembly" section below. Otherwise, continue as described below.



14. Before replacing pump manifold (29), first rotate crankshaft (18) until two outside plungers (24A) extend evenly forward. Next lubricate v-sleeves (50) in the rear v-sleeve housing (48) and slide housing over plungers. Lubricate ceramic plungers with a light film of oil. Carefully and evenly slide manifold over plungers and press manifold firmly against crankcase (1). Replace manifold stud bolts (45), washers (47) and nut (46) and tighten to 35 ft.-lbs.

Gear End Disassembly

NOTE: The manifold (29) weep seal housing (48) and spacer sleeve (26A) must be removed. See above for directions.

15. Remove the crankcase cover screws (9). Inspect the crankcase cover o-ring (4) for wear. Replace if necessary.
16. Inspect the dipstick (5) vent hole for signs of clogging. Clean if necessary.
17. To remove the crankshaft (18), first remove the bearing cover plates (12). Remove the key (19).
18. With a 5 mm allen wrench remove the connecting rod screws (21) and rear portion of connecting rod assemblies (20). Push the connecting rod (20) and plunger rod (22) down as far as possible into the crankcase housing.
19. Hold the pump rear assembly with a wooden fixture, or other suitable device, in order to secure it while removing the crankshaft (18). Using a plastic mallet, tap the crankshaft from one side while turning it from the other side. The turning insures that during this sequence the crankshaft does not become wedged against the front portion of the connecting rods (20). The far side bearing (15) will remain in the crankcase (1). When free, the crankshaft can be removed by hand. The opposite side crankshaft seal (14) will be removed by this procedure. **It is important that you turn the crankshaft (18) constantly while tapping from the opposite end to avoid any binding. The crankshaft bearing (15) remains on the crankshaft as it is removed.** If necessary, use a bearing puller to remove the crankshaft bearing (15).
20. Remove the front portion of the connecting rods (20) and plunger base assembly (22) from the rear of the pump by pulling straight out of the crankcase crosshead guides. **Notice that the connecting rod (20) halves are numbered or colored. Connecting rods must be positioned with their numbers or colors on the upper left-hand side, in the same numerical sequence as when they were removed.**
21. Using a dowel and a rubber mallet, tap the oil seals (26) out from the rear of crankcase (1). The area onto which the oil seal rests should be clean and dry. Put a small drop of loc-tite on the oil seals and place into crankcase with lips facing the rear of the pump.
22. To remove the crosshead pin (23) from the crosshead (22), the assembly should be positioned on a wooden fixture to avoid damage to crosshead. Drive out the pin on opposite side of mark located on the crosshead. On those pumps without mark on crosshead, drive out pin by tapping on tapered side of pin.
23. To remove the bearing (15) remaining in the crankcase (1), insert small end of Giant bearing tool and tap with a rubber mallet until bearing and seal (14) are completely removed. **The bearing can only be removed from the inside by inserting the Giant Bearing Tool through the opposite side of the crankcase.** The crosshead guide in the crankcase should be inspected for possible damage.
24. To reassemble, place the far bearing (15) in the crankcase (1) bearing housing and with the Giant Bearing tool as a driver, tap into the crankcase using a rubber mallet.
25. Insert the far side crankshaft oil seal (14) with the Giant Bearing Tool making sure it is firmly seated and well oiled. Always make sure that the crankshaft seal lip does not show signs of wear and that the garter spring is firmly in place on the seal before reinserting into the pump. Replace the bearing cover (12) and o-ring (13) and tighten securely.

26. Replace the front portion of the connecting rod (20) and plunger rod/ crosshead assembly (22) by press-fitting the crosshead pin (23). Make sure to insert the beveled edge of the crosshead pin into crosshead. If the crosshead has a mark, install pin from marked side. **The crosshead pin (23) should not extend beyond either side of the crosshead (22) in order to prevent damage to the crosshead bore of the crankcase (1).**
27. Place each crosshead/ plunger assembly into the pump making sure that all of the parts are well oiled before insertion into the crankcase (1). **Notice that the connecting rod (20) halves are numbered or colored. Connecting rods must be positioned with their numbers or colors on the upper left-hand side, in the same numerical sequence as when they were removed.**
28. Replace near side bearing (15) on crankshaft by using the Giant Bearing Tool and mallet to tap into place. Take the crankshaft (18) end with the bearing (15) and insert the other end through the bearing housing and tap with a rubber mallet until the bearing is seated.
29. When reassembling the connecting rods (20), note that the connecting rod halves are numbered or colored and that the numbers or colors must be matched and aligned. Torque the connecting rod bolts to 125-150 in.-lbs.
30. Insert the near side crankshaft oil seal (14) with the Giant Bearing Tool making sure it is firmly seated and well oiled. Replace the bearing cover (12) and o-ring (13) and tighten securely.

See instructions above for re-installing fluid end onto the gear end.
31. Fill the P55W / P56W crankcase (1) with 14 oz. of Giant Industries' oil and check the oil level with the dipstick (5). Proper level is center of two lines. Reinstall the pump into your system.

Preventative Maintenance Check-List & Recommended Spare Parts List

Check	Daily	Weekly	50hrs	Every 500 hrs	Every 1500 hrs	Every 3000 hrs
Oil Level/Quality	X					
Oil Leaks	X					
Water Leaks	X					
Belts, Pulley		X				
Plumbing		X				
Recommended Spare Parts						
Oil Change (1 Gallon) p/n 1154			X	X		
Plunger Packing Kits (1 kit/pump) (See page 8 for kit list)					X	
Valve Assembly Kit (1 kit/pump) (See page 8 for kit list)					X	
Oil Seal Kit (1 kit/pump) (See page 8 for kit list)						X

Pump Mounting Selection Guide

<p>Bushings 01056 - 22 mm Tapered H Bushing</p>	<p>Rails 01034 - Steel Box Rails (L=9.25" x W=1.18" x H=1.62") 01075 - Plated Steel Channel Rails (L=9.00" x W=2.12" x H=2.50")</p>
<p>Pulley & Sheaves 01055 - 9.75" Cast Iron - 2 gr.-AB Section 01061 - 7.75" Cast Iron 1 gr. - AB Section 01062 - 7.75" Cast Iron - 2 gr. - AB Section</p>	

P55W / P56W / P56W-HK / P56HT TORQUE SPECIFICATIONS

<u>Position</u>	<u>Item#</u>	<u>Description</u>	<u>Torque Amount</u>
21	01027	Connecting Rod Screw	125-150 in.-lbs.
26D	07202	Bolt Assembly	105 in.-lbs.
41	07213	Plug (Inlet)	50 ft.-lbs.
41A	07034	Plug (Outlet)	50 ft.-lbs.
45	08041	Nut	35 ft.-lbs.

P55W / P56W / P56W-HK / P56HT DIMENSIONS - INCHES (mm)

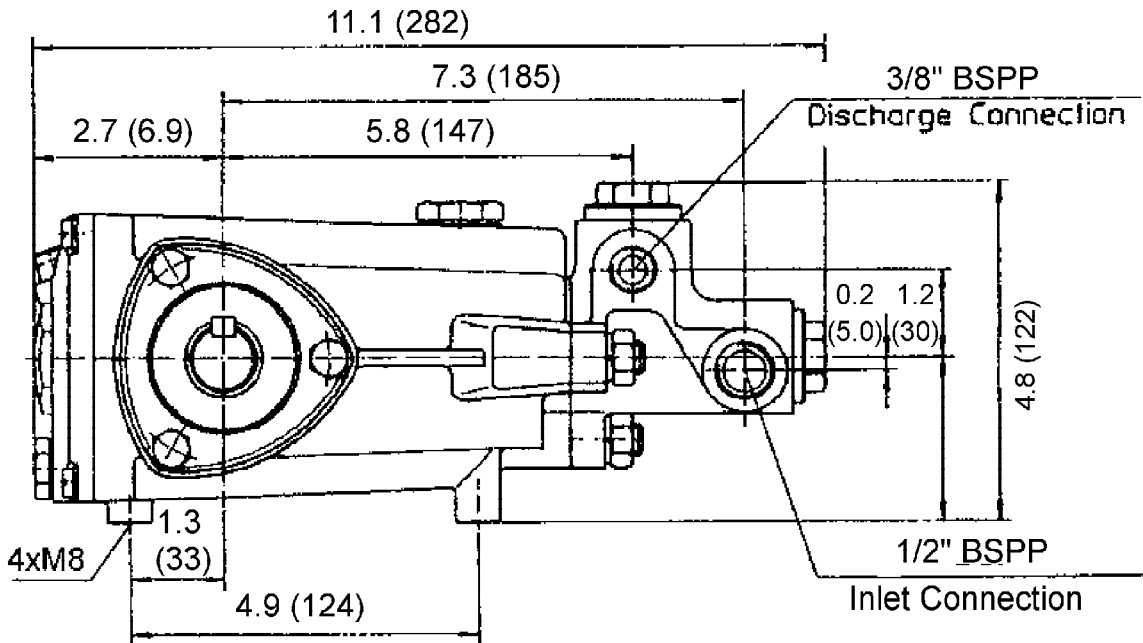
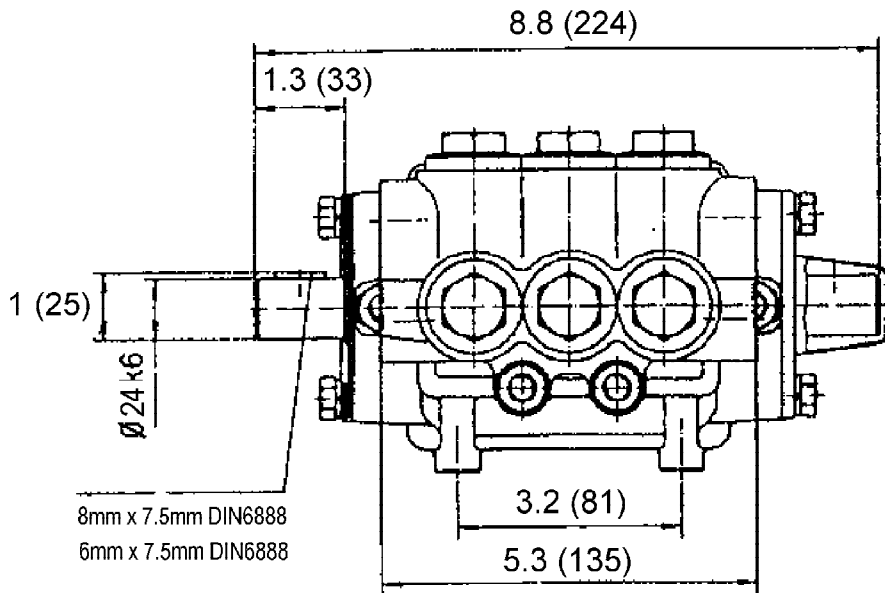

GIANT INDUSTRIES LIMITED WARRANTY

Giant Industries, Inc. pumps and accessories are warranted by the manufacturer to be free from defects in workmanship and material as follows:

1. For portable pressure washers and car wash applications, the discharge manifolds will never fail, period. If they ever fail, we will replace them free of charge. Our other pump parts, used in portable pressure washers and in car wash applications, are warranted for five years from the date of shipment for all pumps used in NON-SALINE, clean water applications.
2. One (1) year from the date of shipment for all other Giant industrial and consumer pumps.
3. Six (6) months from the date of shipment for all rebuilt pumps.
4. Ninety (90) days from the date of shipment for all Giant accessories.

This warranty is limited to repair or replacement of pumps and accessories of which the manufacturer's evaluation shows were defective at the time of shipment by the manufacturer. The following items are NOT covered or will void the warranty:

1. Defects caused by negligence or fault of the buyer or third party.
2. Normal wear and tear to standard wear parts.
3. Use of repair parts other than those manufactured or authorized by Giant.
4. Improper use of the product as a component part.
5. Changes or modifications made by the customer or third party.
6. The operation of pumps and or accessories exceeding the specifications set forth in the Operations Manuals provided by Giant Industries, Inc.

Liability under this warranty is on all non-wear parts and limited to the replacement or repair of those products returned freight prepaid to Giant Industries which are deemed to be defective due to workmanship or failure of material. A Returned Goods Authorization (R.G.A.) number and completed warranty evaluation form is required prior to the return to Giant Industries of all products under warranty consideration. Call (419)-531-4600 or fax (419)-531-6836 to obtain an R.G.A. number.

Repair or replacement of defective products as provided is the sole and exclusive remedy provided hereunder and the MANUFACTURER SHALL NOT BE LIABLE FOR FURTHER LOSS, DAMAGES, OR EXPENSES, INCLUDING INCIDENTAL AND CONSEQUENTIAL DAMAGES DIRECTLY OR INDIRECTLY ARISING FROM THE SALE OR USE OF THIS PRODUCT.

THE LIMITED WARRANTY SET FORTH HEREIN IS IN LIEU OF ALL OTHER WARRANTIES OR REPRESENTATION, EXPRESS OR IMPLIED, INCLUDING WITHOUT LIMITATION ANY WARRANTIES OR MERCHANTABILITY OR FITNESS FOR A PARTICULAR PURPOSE AND ALL SUCH WARRANTIES ARE HEREBY DISCLAIMED AND EXCLUDED BY THE MANUFACTURER.



GIANT INDUSTRIES, INC., 900 N. Westwood Ave., P.O. Box 3187, Toledo, Ohio 43607
PHONE (419) 531-4600, FAX (419) 531-6836, www.giantpumps.com
© Copyright 2002 Giant Industries, Inc.