

# Series P200-18mm versions

Triplex Ceramic  
Plunger Pump  
Operating Instructions/  
Repair and Service  
Manual



For Models:

P217

P218

P219

P220

P221

P227

P230

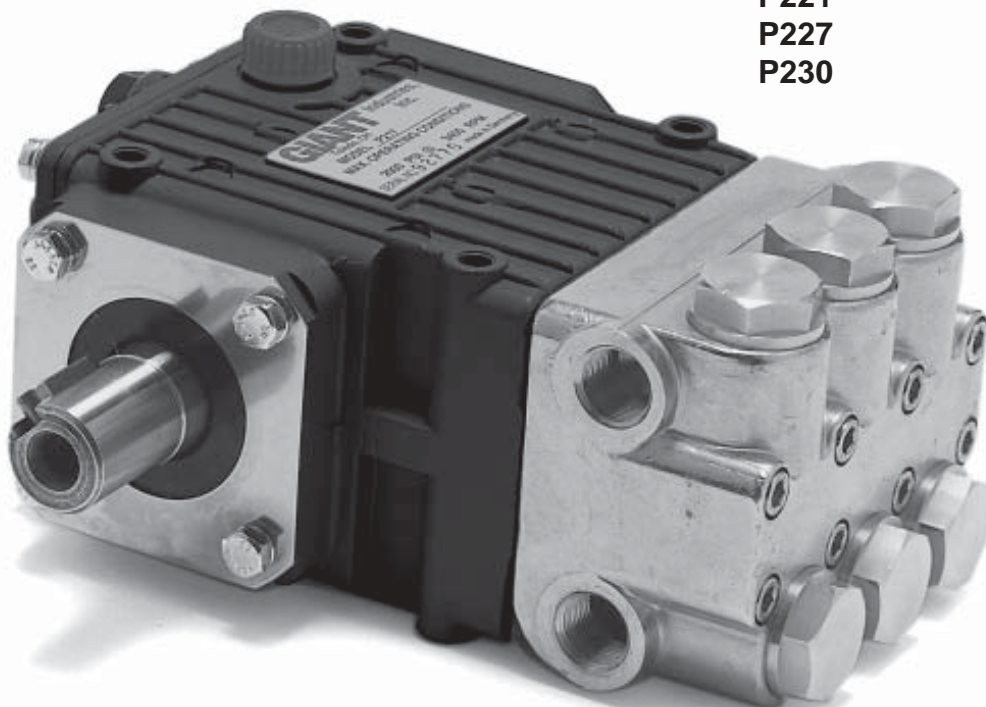

## Contents:

Installation Instructions:	page 2
Pump Specifications:	pages 3-9
Exploded View:	page 10
Parts List:	page 11
Kits & Torque Specifications:	page 12
Pump Mounting Selection Guide:	page 12
Trouble Shooting:	page 13
Recommended Spare Parts List:	page 13
Repair Instructions:	pages 14-15
Dimensions:	back page
Warranty Information:	back page

Updated 12/08

# INSTALLATION INSTRUCTIONS

**Installation of the Giant Industries, Inc., pump is not a complicated procedure, but there are some basic steps common to all pumps. The following information is to be considered as a general outline for installation. If you have unique requirements, please contact Giant Industries, Inc. or your local distributor for assistance.**

1. The pump should be installed flat on a base to a maximum of a 15 degree angle of inclination to ensure optimum lubrication.
2. The inlet to the pump should be sized for the flow rate of the pump with no unnecessary restrictions that can cause cavitation. Teflon tape should be used to seal all joints. If pumps are to be operated at temperatures in excess of 160<sup>o</sup> F, it is important to insure a positive head to the pump to prevent cavitation.
3. The discharge plumbing from the pump should be properly sized to the flow rate to prevent line pressure loss to the work area. It is essential to provide a safety bypass valve between the pump and the work area to protect the pump from pressure spikes in the event of a blockage or the use of a shut-off gun.

4. Use of a dampener is necessary to minimize pulsation at drive elements, plumbing, connections, and other system areas. The use of a dampener with Giant Industries, Inc. pumps is optional, although recommended by Giant Industries, Inc. to further reduce system pulsation. Dampeners can also reduce the severity of pressure spikes that occur in systems using a shut-off gun. A dampener must be positioned downstream from the unloader.

5. Crankshaft rotation on Giant Industries, Inc. pumps should be made in the direction designated by the arrows on the pump crankcase. Reverse rotation may be safely achieved by following a few guidelines available upon request from Giant Industries, Inc. Required horsepower for system operation can be obtained from the charts on pages 3-9.

6. Before beginning operation of your pumping system, remember: Check that the crankcase and seal areas have been properly lubricated per recommended schedules. Do not run the pump dry for extended periods of time. Cavitation will result in severe damage. Always remember to check that all plumbing valves are open and that pumped media can flow freely to the inlet of the pump.

Finally, remember that high pressure operation in a pump system has many advantages. But, if it is used carelessly and without regard to its potential hazard, it can cause serious injury.

---

## IMPORTANT OPERATING CONDITIONS

**Failure to comply with any of these conditions invalidates the warranty.**

1. Prior to initial operation, add oil to the crankcase so that oil level is between the two lines on the oil dipstick. **DO NOT OVERFILL.**

### **Use Giant 20W-50 oil (p/n 01153)**

Crankcase oil should be changed after the first 50 hours of operation, then at regular intervals of 500 hours or less depending on operating conditions.

2. Pump operation must not exceed rated pressure, volume, or RPM. A pressure relief device must be installed in the discharge of the system.

3. Acids, alkalines, or abrasive fluids cannot be pumped unless approval in writing is obtained before operation from Giant Industries, Inc.

4. Run the pump dry approximately 10 seconds to drain the water before exposure to freezing temperatures.

# Specifications

## Model P217

U.S. .... Metric

**1750 RPM<sup>+</sup>**  
 Flow (Continuous) @ 2000 PSI (140 Bar) ..... 1.8 GPM ..... 6.8 LPM  
 Flow (Intermittent) @ 2500 PSI (175 Bar) ..... 1.8 GPM ..... 6.8 LPM

**3450 RPM<sup>+</sup>**  
 Flow (Continuous) @ 2000 PSI (140 Bar) ..... 3.3 GPM ..... 12.5 LPM  
 Flow (Intermittent) @ 2500 PSI (175 Bar) ..... 3.3 GPM ..... 12.5 LPM  
 Maximum Inlet Pressure ..... 145 PSI ..... 10 bar  
 Plunger Diameter ..... 0.71" ..... 18 mm  
 Stroke ..... 0.22" ..... 5.5 mm  
 Max. Temperature of Pumped Fluids ..... 160° F\*\* ..... 71°C\*\*  
 Inlet Ports ..... (2) 1/2" BSP  
 Discharge Ports ..... (2) 3/8" BSP  
 Shaft Rotation ..... Top of Pulley Towards Fluid End  
 Crankshaft Diameter ..... 0.98" ..... 24 mm  
 Key Width ..... 0.31" ..... 8 mm  
 Shaft Mounting ..... Right Side Facing Manifold  
 Weight ..... 11.7 lbs. ..... 5.3 Kg  
 Crankcase Oil Capacity ..... 7.5 fl.oz. ..... 0.22 Liter  
 Extended Crankcase Oil Capacity ..... 9.0 fl.oz. ..... (0.27 Liter  
 Volumetric Efficiency @ 1750 RPM ..... 0.94  
 Volumetric Efficiency @ 3450 RPM ..... 0.87  
 Mechanical Efficiency @ 3450 RPM ..... 0.86

<sup>+</sup>Positive inlet pressure required

**\*\***For P217-HK pump the rating is 195° F (80° C) @ 1.8GPM (6.8LPM) @ 2000PSI (140bar).

Consult the factory for special requirements that must be met if the pump is to operate beyond one or more of the limits specified above.

**NOTE:**

**In order to drive the pump from the side opposite the present shaft extension, simply remove the valve casing from the crankcase and rotate the pumps 180 degrees to the desired position. Be certain to rotate the seal case (item #20) as well, so that the weep holes are down at the six o'clock position. Exchange the oil fill and the oil drain plugs, also. Refer to the repair instructions as necessary for the proper assembly sequence.**

P217 HORSEPOWER REQUIREMENTS					
RPM	GPM	1000 PSI	1500 PSI	2000 PSI	2500 PSI*
250	0.3	0.2	0.3	0.4	0.4
500	0.5	0.4	0.5	0.7	0.9
1000	1.0	0.7	1.1	1.4	1.8
1450	1.5	1.0	1.5	2.1	2.6
1750	1.8	1.2	1.9	2.5	3.1
3000	2.9	2.0	3.0	4.0	5.0
3200	3.1	2.1	3.2	4.2	5.3
3450	3.3	2.3	3.4	4.6	5.7

\*Intermittent duty only

**HORSEPOWER RATINGS:**

The rating shown are the power requirements for the pump. Gas engine power outputs must be approximately twice the pump power requirements shown above.

We recommend a 1.15 service factor be specified when selecting an electric motor as the power source. To compute specific pump horse power requirements, use the following formula:

$$HP = (GPM \times PSI) / 1450$$

# Specifications Model P218

	U.S.	Metric
Flow .....	3.4 GPM	12.9 LPM
Pressure (Continuous) .....	2000 PSI	140 Bar
Pressure (Intermittent) .....	2500 PSI	175 Bar
Maximum Crankshaft Speed .....	1750 RPM	
Maximum Inlet Pressure .....	145 PSI	10 bar
Plunger Diameter .....	0.71"	18 mm
Stroke .....	0.39"	10.0 mm
Max. Temperature of Pumped Fluids .....	160° F**	71°C**
Inlet Ports .....	(2) 1/2" BSP	
Discharge Ports .....	(2) 3/8" BSP	
Shaft Rotation .....	Top of Pulley Towards Fluid End	
Crankshaft Diameter .....	0.98"	24 mm
Key Width .....	0.31"	8 mm
Shaft Mounting .....	Right Side Facing Manifold	
Weight .....	11.7 lbs.	5.3 Kg
Crankcase Oil Capacity .....	7.5 fl.oz.	0.22 Liter
Extended Crankcase Oil Capacity .....	9.0 fl.oz.	(0.27 Liter
Volumetric Efficiency @ 1750 RPM .....	0.94	
Volumetric Efficiency @ 3450 RPM .....	0.87	
Mechanical Efficiency @ 3450 RPM .....	0.86	

\*\* For P218-HK pump the rating is 195° F (80° C) @ 3.4GPM (12.9LPM) @ 2000PSI (140bar).

Consult the factory for special requirements that must be met if the pump is to operate beyond one or more of the limits specified above.

**NOTE:**

**In order to drive the pump from the side opposite the present shaft extension, simply remove the valve casing from the crankcase and rotate the pumps 180 degrees to the desired position. Be certain to rotate the seal case (item #20) as well, so that the weep holes are down at the six o'clock position. Exchange the oil fill and the oil drain plugs, also. Refer to the repair instructions as necessary for the proper assembly sequence.**

P218 HORSEPOWER REQUIREMENTS					
RPM	GPM	1000 PSI	1500 PSI	2000 PSI	2500 PSI*
250	0.5	0.3	0.5	0.7	0.8
500	1.0	0.7	1.0	1.3	1.7
1000	1.9	1.3	2.0	2.7	3.4
1450	2.8	1.9	2.9	3.9	4.9
1750	3.4	2.3	3.5	4.7	5.9

**\*Intermittent duty only**

**HORSEPOWER RATINGS:**

The rating shown are the power requirements for the pump. Gas engine power outputs must be approximately twice the pump power requirements shown above.

We recommend a 1.15 service factor be specified when selecting an electric motor as the power source. To compute specific pump horse power requirements, use the following formula:

$$HP = (GPM \times PSI) / 1450$$

# Specifications Model P219

	U.S. ....	Metric
Flow .....	4.2 GPM	15.9 LPM
Pressure (Continuous) .....	2000 PSI	140 Bar
Pressure (Intermittent) .....	2500 PSI	175 Bar
Maximum Crankshaft Speed .....	1750 RPM	
Maximum Inlet Pressure .....	145 PSI	10 bar
Plunger Diameter .....	0.71"	18 mm
Stroke .....	0.49"	12.4 mm
Max. Temperature of Pumped Fluids .....	160° F**	71°C**
Inlet Ports .....	(2) 1/2" BSP	
Discharge Ports .....	(2) 3/8" BSP	
Shaft Rotation .....	Top of Pulley Towards Fluid End	
Crankshaft Diameter .....	0.98"	24 mm
Key Width .....	0.31"	8 mm
Shaft Mounting .....	Right Side Facing Manifold	
Weight .....	11.7 lbs.	5.3 Kg
Crankcase Oil Capacity .....	7.5 fl.oz.	0.22 Liter
Extended Crankcase Oil Capacity .....	9.0 fl.oz.	(0.27 Liter
Volumetric Efficiency @ 1750 RPM .....	0.94	
Volumetric Efficiency @ 3450 RPM .....	0.87	
Mechanical Efficiency @ 3450 RPM .....	0.86	

\*\*For P219-HK pump the rating is 195° F (80° C) @ 4.2GPM (15.9LPM) @ 2000PSI (140bar).

Consult the factory for special requirements that must be met if the pump is to operate beyond one or more of the limits specified above.

**NOTE:**

**In order to drive the pump from the side opposite the present shaft extension, simply remove the valve casing from the crankcase and rotate the pumps 180 degrees to the desired position. Be certain to rotate the seal case (item #20) as well, so that the weep holes are down at the six o'clock position. Exchange the oil fill and the oil drain plugs, also. Refer to the repair instructions as necessary for the proper assembly sequence.**

P219 HORSEPOWER REQUIREMENTS					
RPM	GPM	1000 PSI	1500 PSI	2000 PSI	2500 PSI
250	0.6	0.4	0.6	0.8	1.0
500	1.2	0.8	1.2	1.7	2.1
1000	2.4	1.7	2.5	3.3	4.1
1450	3.5	2.4	3.6	4.8	6.0
1750	4.2	2.9	4.3	5.8	7.2

**\*Intermittent duty only**

**HORSEPOWER RATINGS:**

The rating shown are the power requirements for the pump. Gas engine power outputs must be approximately twice the pump power requirements shown above.

We recommend a 1.15 service factor be specified when selecting an electric motor as the power source. To compute specific pump horse power requirements, use the following formula:

$$HP = (GPM \times PSI) / 1450$$

# Specifications

## Model P220

	U.S. ....	Metric
Flow .....	4.7 GPM .....	17.8 LPM
Pressure (Continuous) .....	2000 PSI .....	140 Bar
Pressure (Intermittent) .....	2500 PSI .....	175 Bar
Maximum Crankshaft Speed .....	1750 RPM	
Maximum Inlet Pressure .....	145 PSI .....	10 bar
Plunger Diameter .....	0.71" .....	18 mm
Stroke .....	0.56" .....	14.1 mm
Max. Temperature of Pumped Fluids .....	160° F** .....	71°C**
Inlet Ports .....	(2) 1/2" BSP	
Discharge Ports .....	(2) 3/8" BSP	
Shaft Rotation .....	Top of Pulley Towards Fluid End	
Crankshaft Diameter .....	0.98" .....	24 mm
Key Width .....	0.31" .....	8 mm
Shaft Mounting .....	Right Side Facing Manifold	
Weight .....	11.7 lbs. ....	5.3 Kg
Crankcase Oil Capacity .....	7.5 fl.oz. ....	0.22 Liter
Extended Crankcase Oil Capacity .....	9.0 fl.oz. ....	(0.27 Liter
Volumetric Efficiency @ 1750 RPM .....	0.94	
Volumetric Efficiency @ 3450 RPM .....	0.87	
Mechanical Efficiency @ 3450 RPM .....	0.86	

\*\*For P220-HK pump the rating is 195° F (80° C) @ 4.7GPM (17.8LPM) @ 2000PSI (140bar).

Consult the factory for special requirements that must be met if the pump is to operate beyond one or more of the limits specified above.

**NOTE:**

In order to drive the pump from the side opposite the present shaft extension, simply remove the valve casing from the crankcase and rotate the pumps 180 degrees to the desired position. Be certain to rotate the seal case (item #20) as well, so that the weep holes are down at the six o'clock position. Exchange the oil fill and the oil drain plugs, also. Refer to the repair instructions as necessary for the proper assembly sequence.

P220 HORSEPOWER REQUIREMENTS						
RPM	GPM	1000 PSI	1500 PSI	1750 PSI	2000 PSI	2500 PSI*
250	0.7	0.5	0.7	0.8	1.0	1.2
500	1.3	0.9	1.3	1.6	1.8	2.2
1000	2.7	1.9	2.8	3.1	3.7	4.7
1450	3.9	2.7	4.0	4.6	5.4	6.7
1750	4.7	3.2	4.9	5.5	6.5	

\*Intermittent duty only

**HORSEPOWER RATINGS:**

The rating shown are the power requirements for the pump. Gas engine power outputs must be approximately twice the pump power requirements shown above.

We recommend a 1.15 service factor be specified when selecting an electric motor as the power source. To compute specific pump horse power requirements, use the following formula:

$$HP = (GPM \times PSI) / 1450$$

# Specifications Model P221

U.S. .... Metric

<b>1750 RPM<sup>+</sup></b>	
Flow (Continuous) @ 2000 PSI (140 Bar) .....	2.3 GPM ..... 8.9 LPM
Flow (Intermittent) @ 2500 PSI (175 Bar) .....	2.3 GPM ..... 8.9 LPM
<b>3450 RPM<sup>+</sup></b>	
Flow (Continuous) @ 2000 PSI (140 Bar) .....	4.2 GPM ..... 15.9 LPM
Flow (Intermittent) @ 2500 PSI (175 Bar) .....	4.2 GPM ..... 15.9 LPM
Maximum Inlet Pressure .....	145 PSI ..... 10 bar
Plunger Diameter .....	0.71" ..... 18 mm
Stroke .....	0.28" ..... 7.0 mm
Max. Temperature of Pumped Fluids .....	160° F** ..... 71°C**
Inlet Ports .....	(2) 1/2" BSP
Discharge Ports .....	(2) 3/8" BSP
Shaft Rotation .....	Top of Pulley Towards Fluid End
Crankshaft Diameter .....	0.98" ..... 24 mm
Key Width .....	0.31" ..... 8 mm
Shaft Mounting .....	Right Side Facing Manifold
Weight .....	11.7 lbs. .... 5.3 Kg
Crankcase Oil Capacity .....	7.5 fl.oz. .... 0.22 Liter
Extended Crankcase Oil Capacity .....	9.0 fl.oz. .... 0.27 Liter
Volumetric Efficiency @ 1750 RPM .....	0.94
Volumetric Efficiency @ 3450 RPM .....	0.87
Mechanical Efficiency @ 3450 RPM .....	0.86

<sup>+</sup>Positive inlet pressure required

\*\*For P221-HK pump the rating is 195° F (80° C) @ 2.3GPM (8.9LPM) @ 2000PSI (140bar).

Consult the factory for special requirements that must be met if the pump is to operate beyond one or more of the limits specified above.

**NOTE:**

**In order to drive the pump from the side opposite the present shaft extension, simply remove the valve casing from the crankcase and rotate the pumps 180 degrees to the desired position. Be certain to rotate the seal case (item #20) as well, so that the weep holes are down at the six o'clock position. Exchange the oil fill and the oil drain plugs, also. Refer to the repair instructions as necessary for the proper assembly sequence.**

P 221 HORSEPOWER REQUIREMENTS					
RPM	GPM	1000 PSI	1500 PSI	2000 PSI	2500 PSI*
250	0.3	0.2	0.3	0.5	0.6
500	0.7	0.5	0.7	0.9	1.2
1000	1.3	0.9	1.4	1.8	2.3
1450	1.9	1.3	2.0	2.7	3.3
1750	2.3	1.6	2.4	3.2	4.0
3000	3.7	2.5	3.8	5.0	6.3
3200	3.9	2.7	4.0	5.4	6.7
3450	4.2	2.9	4.3	5.8	

\*Intermittent duty only

**HORSEPOWER RATINGS:**

The rating shown are the power requirements for the pump. Gas engine power outputs must be approximately twice the pump power requirements shown above.

We recommend a 1.15 service factor be specified when selecting an electric motor as the power source. To compute specific pump horsepower requirements, use the following formula:

$$HP = (GPM \times PSI) / 1450$$

# Specifications

## Model P227

U.S. .... Metric

<b>1750 RPM<sup>+</sup></b>		
Flow (Continuous) @ 2000 PSI (140 Bar) .....	2.1 GPM .....	8.0 LPM
Flow (Intermittent) @ 2500 PSI (175 Bar) .....	2.1 GPM .....	8.0 LPM
<b>3450 RPM<sup>+</sup></b>		
Flow (Continuous) @ 2000 PSI (140 Bar) .....	3.8 GPM .....	14.4 LPM
Flow (Intermittent) @ 2500 PSI (175 Bar) .....	3.8 GPM .....	14.4 LPM
Maximum Inlet Pressure .....	145 PSI .....	10 bar
Plunger Diameter .....	0.71" .....	18 mm
Stroke .....	0.25" .....	6.3 mm
Max. Temperature of Pumped Fluids .....	160° F** .....	71°C**
Inlet Ports .....	(2) 1/2" BSP	
Discharge Ports .....	(2) 3/8" BSP	
Shaft Rotation .....	Top of Pulley Towards Fluid End	
Crankshaft Diameter .....	0.98" .....	24 mm
Key Width .....	0.31" .....	8 mm
Shaft Mounting .....	Right Side Facing Manifold	
Weight .....	11.7 lbs. ....	5.3 Kg
Crankcase Oil Capacity .....	7.5 fl.oz. ....	0.22 Liter
Extended Crankcase Oil Capacity .....	9.0 fl.oz. ....	(0.27 Liter
Volumetric Efficiency @ 1750 RPM .....	0.94	
Volumetric Efficiency @ 3450 RPM .....	0.87	
Mechanical Efficiency @ 3450 RPM .....	0.86	

<sup>+</sup>Positive inlet pressure require  
<sup>\*\*</sup>For P227-HK pump the rating is 195° F (80° C) @ 2.1GPM (8.0LPM) @ 2000PSI (140bar).

Consult the factory for special requirements that must be met if the pump is to operate beyond one or more of the limits specified above.

**NOTE:**

**In order to drive the pump from the side opposite the present shaft extension, simply remove the valve casing from the crankcase and rotate the pumps 180 degrees to the desired position. Be certain to rotate the seal case (item #20) as well, so that the weep holes are down at the six o'clock position. Exchange the oil fill and the oil drain plugs, also. Refer to the repair instructions as necessary for the proper assembly sequence.**

P 227 HORSEPOWER REQUIREMENTS					
RPM	GPM	1000 PSI	1500 PSI	2000 PSI	2500 PSI*
250	0.3	0.2	0.3	0.4	0.5
500	0.6	0.4	0.6	0.8	1.0
1000	1.2	0.8	1.2	1.7	2.1
1450	1.7	1.2	1.8	2.4	3.0
1750	2.1	1.4	2.2	2.9	3.6
3000	3.3	2.3	3.4	4.6	5.7
3200	3.5	2.4	3.6	4.9	6.1
3450	3.8	2.6	3.9	5.2	6.5

\*Intermittent duty only

**HORSEPOWER RATINGS:**

The rating shown are the power requirements for the pump. Gas engine power outputs must be approximately twice the pump power requirements shown above.

We recommend a 1.15 service factor be specified when selecting an electric motor as the power source. To compute specific pump horsepower requirements, use the following formula:

$$HP = (GPM \times PSI) / 1450$$



# Specifications Model P230

U.S. .... Metric

**1750 RPM<sup>†</sup>**

Flow (Continuous) @ 2000 PSI (140 Bar) ..... 1.1 GPM ..... 4.2 LPM  
 Flow (Intermittent) @ 2500 PSI (175 Bar) ..... 1.1 GPM ..... 4.2 LPM

**3450 RPM<sup>†</sup>**

Flow (Continuous) @ 2000 PSI (140 Bar) ..... 2.0 GPM ..... 7.8 LPM  
 Flow (Intermittent) @ 2500 PSI (175 Bar) ..... 2.0 GPM ..... 7.8 LPM  
 Maximum Inlet Pressure ..... 145 PSI ..... 10 bar  
 Plunger Diameter ..... 0.71" ..... 18 mm  
 Stroke ..... 0.13" ..... 3.4 mm  
 Max. Temperature of Pumped Fluids ..... 160° F\*\* ..... 71°C\*\*  
 Inlet Ports ..... (2) 1/2" BSP  
 Discharge Ports ..... (2) 3/8" BSP  
 Shaft Rotation ..... Top of Pulley Towards Fluid End  
 Crankshaft Diameter ..... 0.98" ..... 24 mm  
 Key Width ..... 0.31" ..... 8 mm  
 Shaft Mounting ..... Right Side Facing Manifold  
 Weight ..... 11.7 lbs. ..... 5.3 Kg  
 Crankcase Oil Capacity ..... 7.5 fl.oz. ..... 0.22 Liter  
 Extended Crankcase Oil Capacity ..... 9.0 fl.oz. ..... (0.27 Liter  
 Volumetric Efficiency @ 1750 RPM ..... 0.94  
 Volumetric Efficiency @ 3450 RPM ..... 0.87  
 Mechanical Efficiency @ 3450 RPM ..... 0.86

<sup>†</sup>Positive inlet pressure required

\*\*For P230-HK pump the rating is 195° F (80° C) @ 1.1GPM (4.2LPM) @ 2000PSI (140bar).

Consult the factory for special requirements that must be met if the pump is to operate beyond one or more of the limits specified above.

**NOTE:**

**In order to drive the pump from the side opposite the present shaft extension, simply remove the valve casing from the crankcase and rotate the pumps 180 degrees to the desired position. Be certain to rotate the seal case (item #20) as well, so that the weep holes are down at the six o'clock position. Exchange the oil fill and the oil drain plugs, also. Refer to the repair instructions as necessary for the proper assembly sequence.**

<b>P230 HORSEPOWER REQUIREMENTS</b>					
<b>RPM</b>	<b>GPM</b>	<b>1000 PSI</b>	<b>1500 PSI</b>	<b>2000 PSI</b>	<b>2500 PSI*</b>
250	0.2	0.1	0.2	0.2	0.3
500	0.3	0.2	0.3	0.4	0.5
1000	0.6	0.4	0.7	0.9	1.1
1450	0.9	0.6	0.9	1.3	1.6
1750	1.1	0.8	1.1	1.5	1.9
3000	1.8	1.2	1.8	2.5	3.1
3200	1.9	1.3	2.0	2.6	3.3
3450	2.0	1.4	2.1	2.8	3.5

**HORSEPOWER RATINGS:**

The rating shown are the power requirements for the pump. Gas engine power outputs must be approximately twice the pump power requirements shown above.

We recommend a 1.15 service factor be specified when selecting an electric motor as the power source. To compute specific pump horsepower requirements, use the following formula:

$$HP = (GPM \times PSI) / 1450$$

**\*Intermittent duty only**

# Exploded View

P217/P218/P219/P220/P221/P227/P230 Pumps

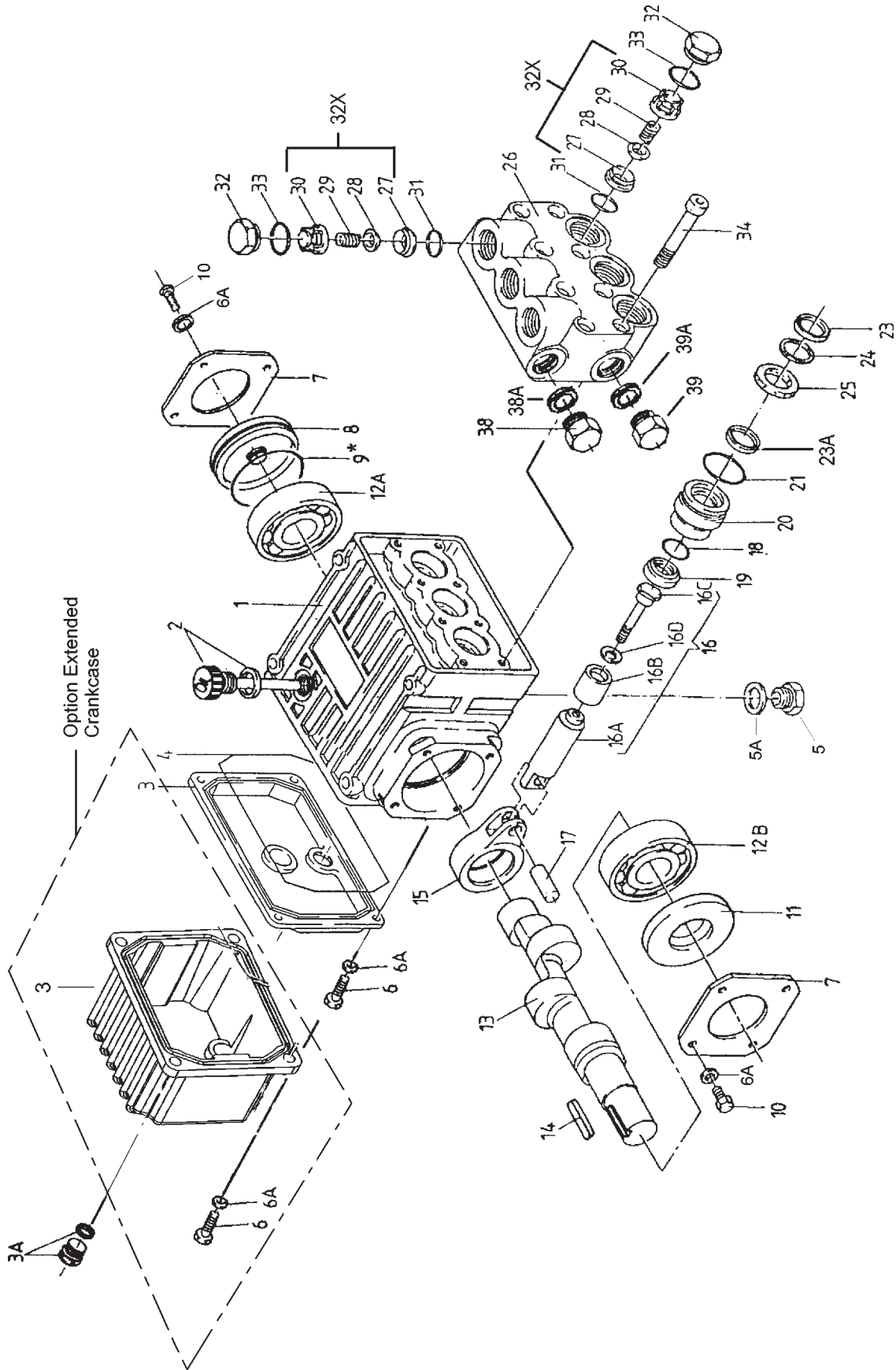

## Spare Parts

### P217/P218/P219/P220/P221/P227/P230 Pumps

<u>ITEM</u>	<u>PARTNO.</u>	<u>DESCRIPTION</u>	<u>QTY.</u>	<u>ITEM</u>	<u>PARTNO.</u>	<u>DESCRIPTION</u>	<u>QTY.</u>
1	08300	Crankcase	1	16A	08468	Plunger Base	3
2	06773	Oil Dipstick with O-Ring	1	16B	08455	Plunger Pipe	3
3	08302	Crankcase Cover, Short	1	16C	08456	Tension Screw	3
3	08302-L	Crankcase Cover, Long	1	16D	07676	Copper Gasket	3
3A	07190	Drain Plug & Gasket	1	17	08442	Wrist Pin	3
4	08005	O-Ring	1	18	07770	O-Ring	3
5	06273	Oil Drain Plug	1	19	08356-0010	Oil Seal	3
5A	08192	Gasket	1	20	08444	Seal Case	3
6	07188	Screw, Crankcase Cover	4	21	08443	O-Ring	3
6A	01176-2	Spring Washer	4	23	08477	V-Sleeve, Weep	3
7	08303	Bearing Cover I	2	23A	08087	V-Sleeve, Brown	3
8	08490	Sight Glass	1	24	07904	Pressure Ring	3
9	08492	O-Ring for Sight Glass	1	25	08445	Weep Return Ring	3
10	07225	Screw with Lock Washer	8	26	06582 <sup>+</sup>	Valve Casing 1/2" Inlet Ports	1
11	01166	Radial Shaft Seal	1	27	07849	Valve Seat	6
12A	08020	Ball Bearing	1	28	07491	Valve Plate	6
12B	01020	Ball Bearing	1	29	07906	Valve Spring	6
13	08465	Crankshaft ( <b>P217</b> )	1	30	07907	Valve Spring Retainer	6
13	08440	Crankshaft ( <b>P218</b> )	1	31	07853	O-Ring	6
13	08466	Crankshaft ( <b>P219</b> )	1	32	07928	Valve Plug	6
13	08467	Crankshaft ( <b>P220</b> )	1	32X	07946	Valve Assembly Complete	6
13	12258	Crankshaft ( <b>P221</b> )	1	33	07913	O-Ring	6
13	06547	Crankshaft ( <b>P227</b> )	1	34	08316	Hex Head Cap Screw	8
13	06694	Crankshaft ( <b>P230</b> )	1	38	13338	Plug, 3/8" BSP	1
14	06207	Woodruff Key	1	38A	08486	Copper Crush Washer, 3/8"	1
15	08333	Connecting Rod	3	39	07109	Plug, 1/2" BSP	1
16	08469	Plunger, Complete, 18mm	3	39A	07661	Seal	1

## Repair Kits

P217/P218/P219/P220/P221/P227/P230 Pumps

### Plunger Packing Kit

#### Part # 09164

<u>Item #</u>	<u>Part #</u>	<u>Description</u>	<u>Qty.</u>
23	08477	V-Sleeve, weep	3
23A	08087	V-Sleeve, brown	3
24	07904	Pressure Ring	3

### Valve Assembly Kit

#### Part # 09116

<u>Item #</u>	<u>Part #</u>	<u>Description</u>	<u>Qty.</u>
32X	07946	Valve Assembly Complete	6
31	07853	O-Ring	6

### Oil Seal Kit

#### Part # 09144

<u>Item #</u>	<u>Part #</u>	<u>Description</u>	<u>Qty.</u>
19	08356-0010	Oil Seal	3

### Pump Mounting Selection Guide

<b>Bushings</b> <b>01074</b> - 24 mm Tapered H Bushing
<b>Pulley &amp; Sheaves</b> <b>01061</b> - 7.75" Cast Iron 1 gr. AB Section <b>01062</b> - 7.75" Cast Iron - 2 gr. AB Section
<b>Rails</b> <b>01160</b> - Plated Steel Channel Rails (L=5.75"x W=1.00"x h=2.50") <b>01161</b> - Plated Steel Channel Rails (L=5.75"x W=1.00"x H=2.50")

### Optional Kits

#### Teflon Plunger Packing Kit

##### Part # 09164-0021

<u>Item #</u>	<u>Part #</u>	<u>Description</u>	<u>Qty.</u>
18	07770-0001	O-Ring, Viton	3
21	08443-0001	O-Ring, Viton	3
23/23A	08087-0020	Weep Seal, Teflon	6
24	07904	Pressure Ring	3
31	07853-0001	O-Ring, Viton	3
33	07913-0001	O-Ring, Viton	3

#### Viton Seal Kit

##### # 09164-0011

<u>Item</u>	<u>Part #</u>	<u>Description</u>	<u>Qty.</u>
18	07770-0001	O-Ring, Viton	3
21	08443-0001	O-Ring, Viton	3
23	07902-0010	V-Sleeve, with support ring, Viton	6
24	07904	Pressure Ring	3
31	07853-0001	O-Ring, Viton	6
33	07913-0001	O-Ring, Viton	6

#### High Temperature Seal Kit

##### # 09599

<u>Item</u>	<u>Part #</u>	<u>Description</u>	<u>Qty.</u>
23/23A	06704	High-Temp Seal	6
24	07904	Pressure Ring	3

## Pump Torque Specifications

P217/P218/P219/P220/P221/P227/P230

<u>Position</u>	<u>Item#</u>	<u>Description</u>	<u>Torque Amount</u>
16C	08456	Tension Screw, Plunger	220 (in.-lbs.)
32	07928	Valve Plug	33 or 59* (ft.-lbs.)
34	08316	Hex Head Cap Screw, Valve Casing	105 (in.-lbs.)

\* For pumps manufactured prior to 5/97, tighten plugs to 33 ft.lbs. Otherwise, tighten to 59 ft.-lbs.

# PUMP SYSTEM MALFUNCTION

<u>MALFUNCTION</u>	<u>CAUSE</u>	<u>REMEDY</u>
The Pressure and/or the Delivery Drops	Worn packing seals Broken valve spring Belt slippage Worn or Damaged nozzle Fouled discharge valve Fouled inlet strainer Worn or Damaged hose Worn or Plugged relief valve on pump Cavitation pump for restrictions Unloader	Replace packing seals Replace spring Tighten or Replace belt Replace nozzle Clean valve assembly Clean strainer Repair/Replace hose Clean, Reset, and Replace worn parts Check suction lines on inlet of  Check for proper operation
Water in crankcase	High humidity Worn seals	Reduce oil change interval Replace seals
Noisy Operation	Worn bearings oil with Cavitation	Replace bearings, Refill crankcase recommended lubricant Check inlet lines for restrictions and/or proper sizing
Rough/Pulsating Operation with Pressure Drop	Worn packing Inlet restriction  Accumulator pressure Unloader Cavitation	Replace packing Check system for stoppage, air leaks, correctly sized inlet plumbing to pump Recharge/Replace accumulator Check for proper operation Check inlet lines for restrictions and/or proper size
Pressure Drop at Gun	Restricted discharge plumbing	Re-size discharge plumbing to flow rate of pump
Excessive Leakage	Worn plungers Worn packing/seals Excessive vacuum Cracked plungers Inlet pressure too high	Replace plungers Adjust or Replace packing seals Reduce suction vacuum Replace plungers Reduce inlet pressure
High Crankcase Temperature	Wrong Grade of oil Improper amount of oil in crankcase	Giant oil is recommended Adjust oil level to proper amount

Preventative Maintenance Check-List & Recommended Spare Parts List						
Check	Daily	Weekly	50hrs	Every 500 hrs	Every 1500 hrs	Every 3000 hrs
Oil Level/Quality	X					
Oil Leaks	X					
Water Leaks	X					
Belts, Pulley		X				
Plumbing		X				
Recommended Spare Parts						
Oil Change (1 Quart) p/n 1153			X	X		
Seal Spare Parts (1 kit/pump) (See page 12 for kit list)					X	
Oil Seal Kit (1 kit/pump) (See page 12 for kit list)					X	
Valve Spare Parts (1 kit/pump) (See page 12 for kit list)						X

# REPAIR INSTRUCTIONS - P217/P218/P219/P220/P221/P227/P230 PUMPS

*NOTE: Always take time to lubricate all metal and nonmetal parts with a light film of oil before reassembly. This step will ensure proper fit, at the same time protecting the pump nonmetal parts (i.e., the elastomers) from cutting and scoring.*

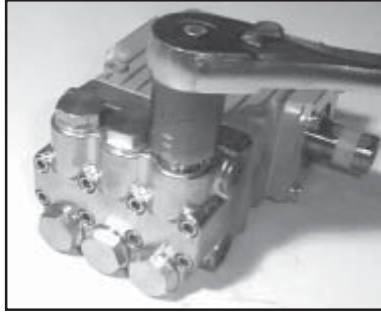

1. With a 22mm socket wrench, remove the (3) discharge valve plugs and (3) inlet valve plugs (32). Inspect the o-ring (33) for wear and replace if damaged.

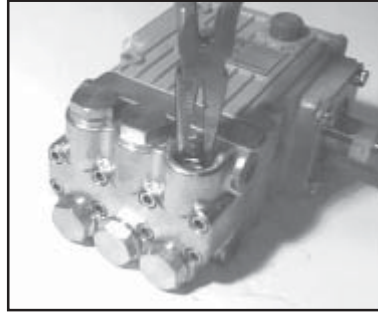

2. Using a needle nose pliers, remove the inlet and discharge valve assemblies (32X).



3. By inserting a small screw driver between the valve seat (27) and the valve spring retainer (30), the valve assembly can be separated.



4. Remove the o-ring (31). Inspect all parts for wear and replace as necessary. Apply one drop of Loctite 243 to the valve plugs (32) and tighten to 59 ft.-lbs.

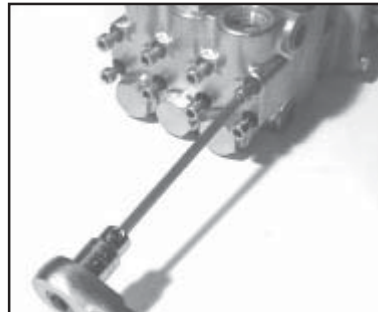

5. Next, use a 5mm allen wrench to remove the 8 socket head cap screws (34).

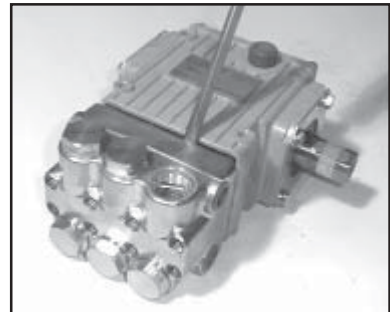

6. Carefully slide the valve casing (26) out over the plungers.



7. Remove the weep return ring (25), pressure ring (24), and v-sleeve (23) from the valve casing (26). Remove the v-sleeve (23A) from the seal case (20). Inspect all parts, including o-ring (21) for wear and replace as

8. necessary  
Check surfaces of plunger (16). A damaged surface will cause accelerated wear on the seals. Deposits of any kind must be carefully removed from the plunger surface. A damaged plunger must be replaced!

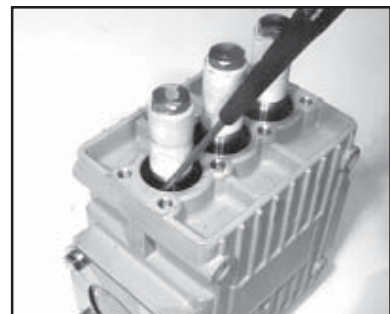

9. If the crankcase oil seals (19) are to be replaced, they can be removed by prying loose with a flat screwdriver. Take care not to make contact with the plunger.

## REPAIR INSTRUCTIONS - P217/P218/P219/P220/P221/P227/P230 PUMPS

10. If the ceramic plunger pipe (16B) is damaged, remove the plunger bolt (16C). Discard the old plunger pipe (16B) and copper gasket (16D), and clean the old locktite from the plunger bolt (16C) and plunger base (16A). Replace the plunger with the new one and locktite the plunger bolt and torque to 220 inch-pounds.

NOTE: If there are deposits of any kind (i.e., lime deposits) in the valve casing, be certain that the weep holes in the weep return ring (25) and valve casing (26) have not been plugged.

### Reassembly sequence of the P217/P218/P219/P220/P221/P227/P230 pumps

- 1) If oil seals (19) were removed, replace with seal lip towards crankcase. Lubricate seals before replacing.
- 2) Replace seal case (20) with o-rings (21) over plungers. Generously lubricate o-rings and oil seal before reassembly. Replace v-sleeve (23A) over plungers (16)..
- 3) Generously lubricate v-sleeve (23). Assemble v-sleeves (22) into valve casing (#26). Assemble weep return ring (25) and pressure ring (24) over plungers (16). Slide valve casing over plungers and seat firmly. Replace the eight socket head cap screws (34) and tighten to 105 inch-pounds in a crossing pattern.
- 4) Replace the six o-rings (31) and the six valve assemblies (32X). Now replace the six valve plug o-rings (33). For pumps manufactured prior to 5/97, tighten plugs (32) to 33 ft.-lbs. otherwise, apply one drop of Loctite 243 to the valve plugs (32) and tighten to 59 ft.-lbs.

**NOTE: Contact Giant Industries for Service School Information. Phone: (419)-531-4600**

## P217/P218/P219/P220/P221/P227/P230 DIMENSIONS - Inches (mm)

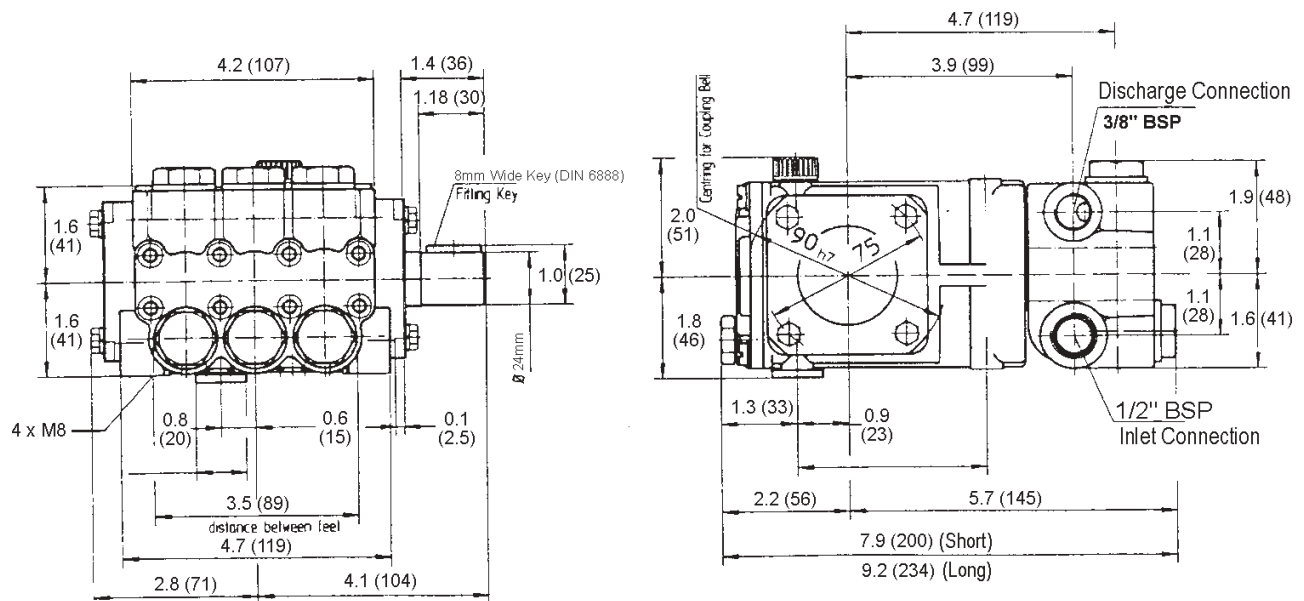

### GIANT INDUSTRIES LIMITED WARRANTY

Giant Industries, Inc. pumps and accessories are warranted by the manufacturer to be free from defects in workmanship and material as follows:

1. For portable pressure washers and self-serve car wash applications, the discharge manifolds will never fail, period. If they ever fail, we will replace them free of charge. Our other pump parts, used in portable pressure washers and in car wash applications, are warranted for five years from the date of shipment for all pumps used in NON-SALINE, clean water applications.
2. One (1) year from the date of shipment for all other Giant industrial and consumer pumps.
3. Six (6) months from the date of shipment for all rebuilt pumps.
4. Ninety (90) days from the date of shipment for all Giant accessories.

This warranty is limited to repair or replacement of pumps and accessories of which the manufacturer's evaluation shows were defective at the time of shipment by the manufacturer. The following items are NOT covered or will void the warranty:

1. Defects caused by negligence or fault of the buyer or third party.
2. Normal wear and tear to standard wear parts.
3. Use of repair parts other than those manufactured or authorized by Giant.
4. Improper use of the product as a component part.
5. Changes or modifications made by the customer or third party.
6. The operation of pumps and or accessories exceeding the specifications set forth in the Operations Manuals provided by Giant Industries, Inc.

Liability under this warranty is on all non-wear parts and limited to the replacement or repair of those products returned freight prepaid to Giant Industries which are deemed to be defective due to workmanship or failure of material. A Returned Goods Authorization (R.G.A.) number and completed warranty evaluation form is required prior to the return to Giant Industries of all products under warranty consideration. Call (419)-531-4600 or fax (419)-531-6836 to obtain an R.G.A. number.

Repair or replacement of defective products as provided is the sole and exclusive remedy provided hereunder and the MANUFACTURER SHALL NOT BE LIABLE FOR FURTHER LOSS, DAMAGES, OR EXPENSES, INCLUDING INCIDENTAL AND CONSEQUENTIAL DAMAGES DIRECTLY OR INDIRECTLY ARISING FROM THE SALE OR USE OF THIS PRODUCT.

THE LIMITED WARRANTY SET FORTH HEREIN IS IN LIEU OF ALL OTHER WARRANTIES OR REPRESENTATION, EXPRESS OR IMPLIED, INCLUDING WITHOUT LIMITATION ANY WARRANTIES OR MERCHANTABILITY OR FITNESS FOR A PARTICULAR PURPOSE AND ALL SUCH WARRANTIES ARE HEREBY DISCLAIMED AND EXCLUDED BY THE MANUFACTURER.



GIANT INDUSTRIES, INC., 900 N. Westwood Ave., P.O. Box 3187, Toledo, Ohio 43607  
 PHONE (419) 531-4600, FAX (419) 531-6836, www.giantpumps.com  
 © Copyright 2008 Giant Industries, Inc.