

PROPRIETARY DATA

PROPERTY OF DEN HARTOG INDUSTRIES, INC. INFORMATION FURNISHED HEREIN IS THE PROPERTY OF DEN HARTOG INDUSTRIES, INC. AND SHALL NOT BE USED, DISCLOSED TO OTHERS, OR COPIED WITHOUT THE EXPRESSED WRITTEN CONSENT OF DEN HARTOG INDUSTRIES, INC. ALL RIGHTS RESERVED.

MATERIAL/PART SCHEDULE

FS125/165-SBPJS



PART#	DESCRIPTION	QTY.
S-14GA	14GA MILD STEEL SHEET	360 SI
SJ10937	3/8" FLAT WASHER	2

FS125/165-SBPJ | 2 PER SET

©

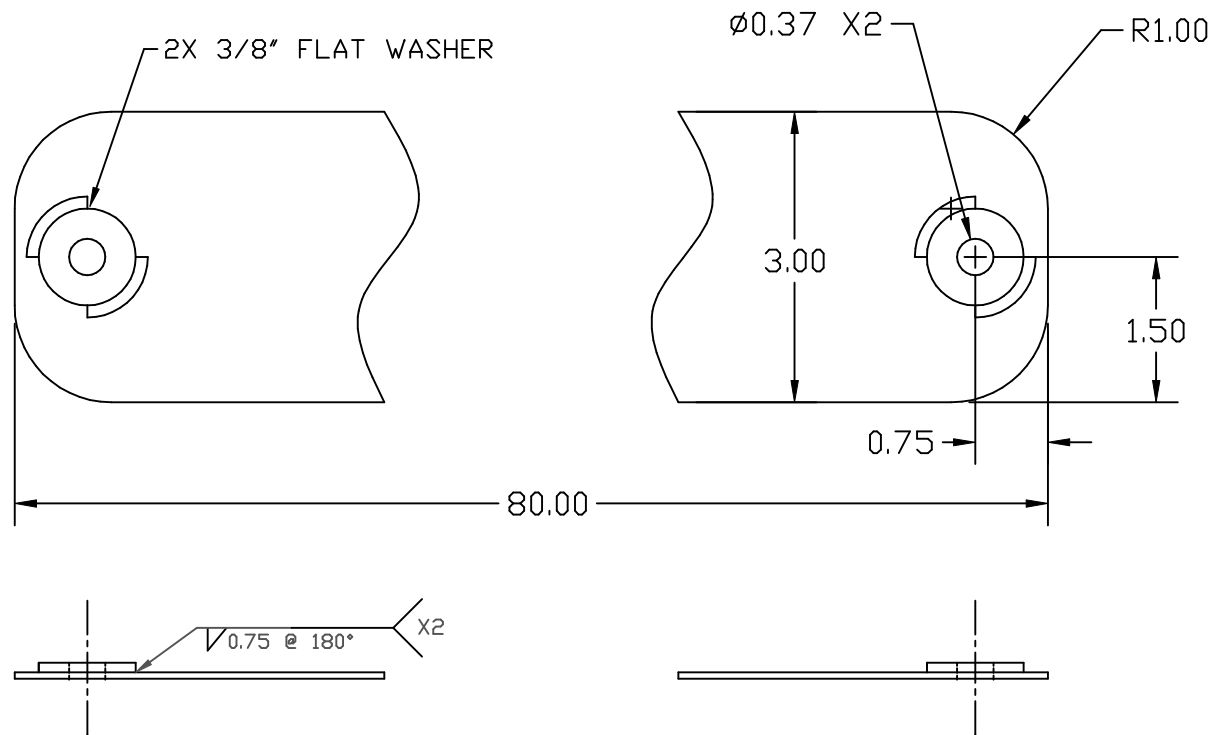

C	ADD TEXT BOX	4/2/07	GWC	DRAWN / DATE	MATERIAL
B	TOLERANCE WAS 1% @ 68° F	3/16/07	GWC	NVE 12/7/05	14GA (.0747) MILD STEEL
A	ADDED WELD DESCRIPTION	6/21/06	NVE	APPRD. / DATE	
REV	DESCRIPTION	DATE	APPRD	REH/1/13/06	
ALL DIMENSIONS ARE IN DECIMAL INCHES TOLERANCES UNLESS OTHERWISE SPECIFIED DECIMAL +/- .125" FRACTION +/- 1/4" ANGLE +/- 2°				THIRD ANGLE PROJECTION ANSI 14.5M	NOTES: 1. POWDER COATED 2. WEIGHT 5.0 LBS.



**ACE ROTO-MOLD**  
A DIVISION OF DEN HARTOG INDUSTRIES, INC.  
4018 HWY. 60 BLVD., BOX 421, HOSPERS, IOWA 51238

CLIENT / DESCRIPTION  
STEEL BAND (FOR J-BOLT) FOR 125 AND 165 GALLON LEG TANKS

SCALE	N.S.	PART NO.	FS125/165-SBPJS
-------	------	----------	-----------------