

31 HP VANGUARD™ Model Series 543400

Displacement 54 cu. in. (895 cc)

Bore 3.366 in. (85.5 mm)

Stroke 3.071 in. (78.0 mm)

Oil Capacity 71 fl. oz. (2.1 l) w/o Filter
79 fl. oz. (2.3 l) w/Filter



COMMERCIAL POWER

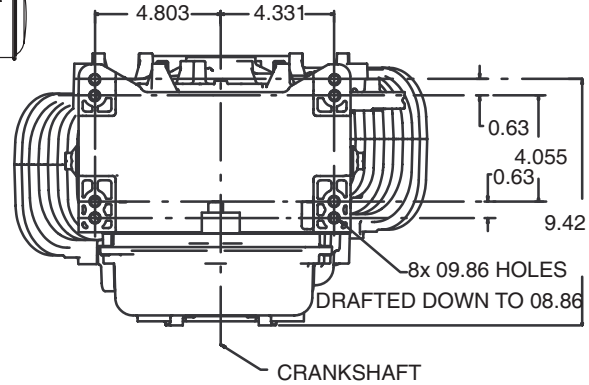
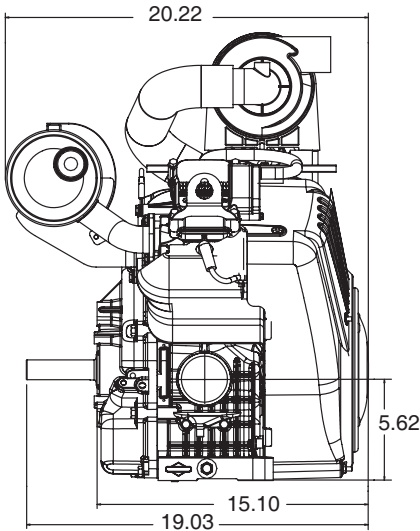
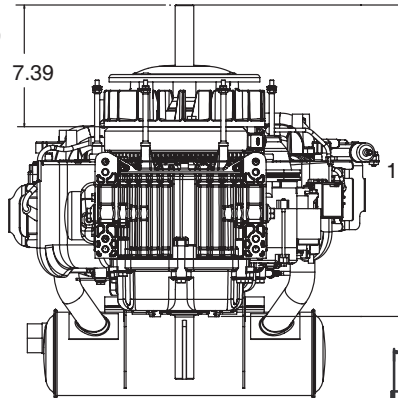
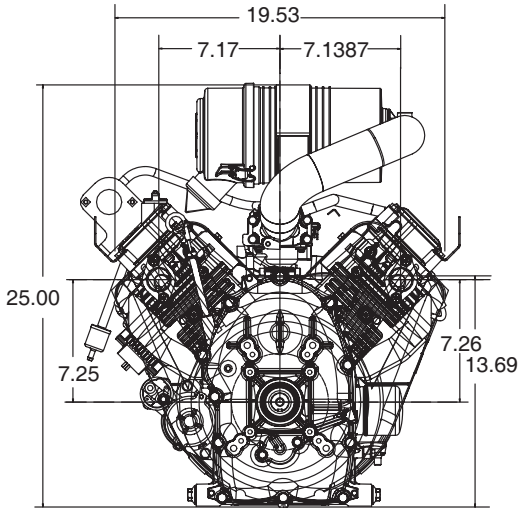

Features:

- Cast iron sleeve assures longer engine life and improved oil control
- Advanced Debris Management System allows the engine to run cleaner and cooler, which enhances durability and performance.
- Foam pre-cleaner traps large debris before it can clog the filter element and rob the engine of needed air.
- Industrial grade solenoid shift starter assures quick, reliable starts.
- Full-pressure oil lubrication system with spin-on filter works to keep oil cleaner, which reduces maintenance and extends engine life.

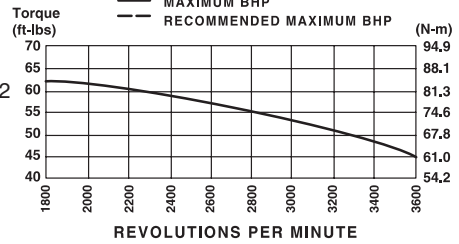
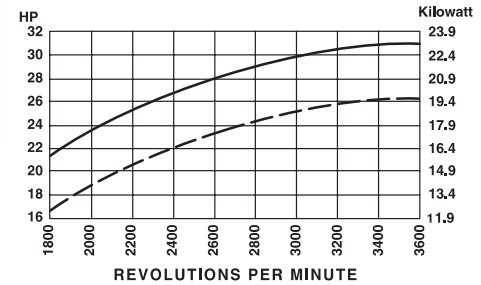

Model Type	Shipping Weight	Crankshaft	Crankshaft (P.T.O.) Extension	Dimension	Starter Position	Bolt-On/Changeable	Oil Filler & Drain	Governor	Controls	Exhaust System	Fuel Tank (Quarts)	Pulse Fuel Pump	Flange Mtg.	Oil Pump w/Filter	Remote Choke	Manual Choke	Top Governor Speed	Notes
543477																		
0048	809982	1-1/8" dia., 1/4" Keyway & Tapped 7/16-20	4 (c)		★	M	MF			■	X	X	X		X		3600	◆
0065	809982	1-1/8" dia., 1/4" Keyway & Tapped 7/16-20	4 (c)		★	M	MF		•	■	X	X	X		X		3600	◆
0076		1-1/8" dia., 1/4" Keyway & Tapped 7/16-20	3 (c)		★	M	R		•	■	X	X	X	X			3600	◆
0079		1-7/16" dia., 3/8" Keyway & Tapped 5/8-18	4-1/2 (c)		★	M	MF		•	■	X	X	X		X		3600	◆
0110	809982	1-1/8" dia., 1/4" Keyway & Tapped 7/16-20	4 (c)		★	M	R			■	X	X	X	X			3600	◆
0111	809982	1-1/8" dia., 1/4" Keyway & Tapped 7/16-20	4 (c)		★	M	R		•	■	X	X	X	X			3600	◆

• Exhaust manifold and muffler omitted. ★ Oil fill and dipstick in cover; dual drain. ■ Fuel tank omitted.
◆ Engine equipped with 12 Volt Gear Drive Starter and 20 Amp DC Alternator.