

9 HP VANGUARD™ Model Series 185400

Displacement 18 cu. in. (296 cc)

Bore 3.15 in. (80 mm)

Stroke 2.32 in. (59 mm)

Oil Capacity 40 fl. oz. (1.19 l)



COMMERCIAL POWER

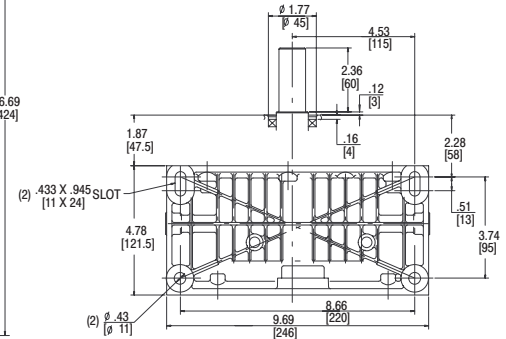
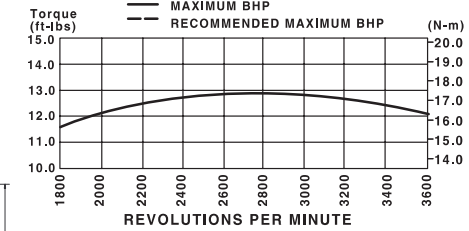
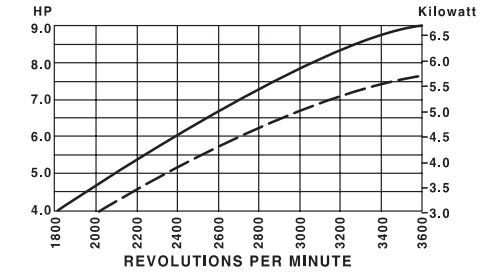
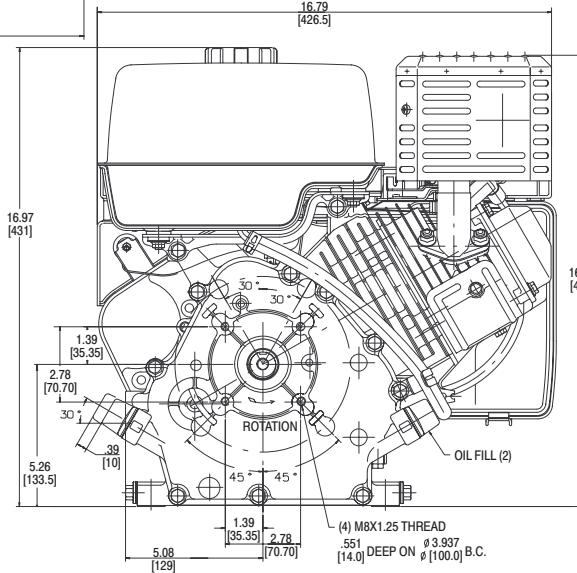
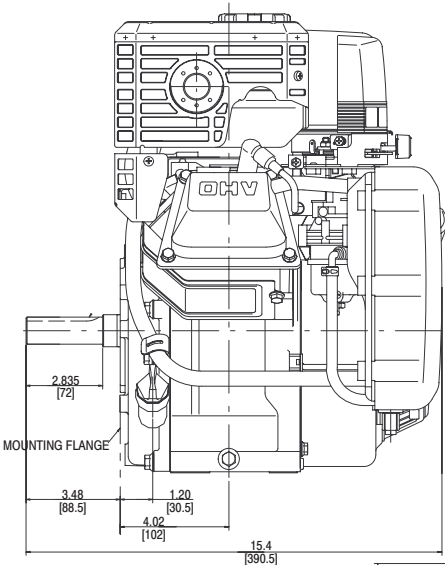

Model Type	Shipping Weight	Crankshaft	Crankshaft (P.T.O.) Extension	Dimension	Starter Position	Bolt-On/Changeable Governor	Controls	Flange Mtg.	Manual Choke	Rocker-Stop Switch	Oil Gard®	Fuel Tank (Quarts)	Top Governor Speed	Notes
185432														
0235	63	715098	1" dia., Keyway, tapped 7/16-20	2-29/32(c)	10:30	M	AG/R/MF	X	X	X	X	8.3	3600	•
0246	62	715098	1" dia., Keyway, tapped 7/16-20	2-29/32(c)	10:30	M	AG/R/MF	X	X	X	X	8.3	3600	•■
0247	63	715100	Threaded 1-14, 1" tapped length	3-21/32(c)	10:30	M	AG/R/MF	X	X	X	X	8.3	3600	•
0270	68	715101	Tapered, tapped 5/16-24	4-11/32(c)	10:30	M	AG	X	X	X	X	8.3	3750	•
185437														
0284	71	715098	1" dia., Keyway, tapped 7/16-20	2-29/32(c)	10:30	M	AG/R/MF	X	X	X	X	8.3	3600	•◆

• Ball bearing PTO and magneto side. ■ Small high mount air cleaner
◆ Engine equipped with 12 Volt Gear Drive Starter and 10 Amp DC Alternator with Starter Panel Assembly.

Features:

- Dura-Bore™ cast iron cylinder sleeve for extended life
- Maintenance-free Magnetron® electronic ignition for quick, dependable starts
- Dual-Clean™ air cleaner pleated paper filter with a foam pre-cleaner ensures maximum protection for extended engine life
- Oil Gard® low oil engine shutdown device
- Overhead valve design (OHV) for cooler operation and longer valve life
- Buyer protection package provides two-year commercial engine warranty