



<http://www.amicousa.com>



AMICO INTERNATIONAL CORP

4825 Gregg Road Pico Rivera, CA 90660 U. S. A.
Tel: 1-888-512-5888 (562) 908 - 0088 Fax: (562) 908 - 1899

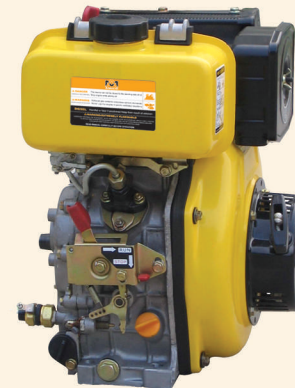

OWNER'S
PLEASE READ THIS MANUAL CAREFULLY.
IT CONTAINS IMPORTANT SAFETY INFORMATION.
MANUAL

Diesel *Engine*

TOLL FREE:1-888-512-5888

AHD170
AHD178
AHD186

CONTENTS

Preface

Safety Information

Engine Specifications	1
Safety Label Location	2
Assembling	2
Engine Usage	3
Start the Engine	6
Electric Wiring Diagram	12
Run the Engine	13
Stop the Engine.....	14
Periodical Check and Maintenance	15
Long-term Storage	18
Detail Diagram	19
Appendix 1.Overall and Installation Dimensions.....	36
Appendix 2.Performance Curve & Sizes Of Pto Flanges.....	37
Appendix 3.Sizes of PTO Flanges & Size of Output Shaft	38
Appendix 4.Malfunction and remedy of diesel engine.....	39
Limited Warranty.....	43
Product Registration Card.....	45



To correctly operate your engine are for your own safety,be sure to read this manual carefully,otherwise the accident will result.

If you have problem about your engine,please contact with sales company or the authorized agent.

PREFACE:

- These manual guides you how to operate air-cooled diesel engine correctly,as well as the warnings,Be sure to read this manual before operating,to keep your engine at the best working condition.
- This manual should be considered as the permanent part of the engine for easy checking up.
- Should this manual missing or destroyed,please make an order from your agent.If you have anything unclear about this manual,please contact your agent.
air-cooled desel engine will meet your requirement if you operate it according to the manual instruction. Otherwise the fire,scald etc serious accident will result.
- So reconfirm that you must to master this manual before operating the engine.



DANGER

Indicates that the serious personal injury even death will result if the instructions are not followed.



WARNING

Indicates that the serious personal injury even death will result if the instructions are not followed.



CAUTION

Indicates that the serious personal injury or equipment damage will result if the instructions are not followed.



[OPERATING NOTICE]

indicates that you must give special attention while operating the engine.Otherwise the engine performance will decreased even the fault will result.Be sure to follow the



[OPERATING NOTICE]

SAFETY INFORMATION

(To operate the engine safely, please follow these items strictly.)

DANGER



To prevent the fire, please pay attention to the following items:

- If the gasoline is filled into the engine, the fire will result, so identify the fuel type and model before refilling.
- Be sure to stop the engine before refilling.
- Wipe off the overflowed fuel oil.
- Keep the engine far away from other flammable oils and goods.

DANGER



Be careful when use the battery:

- The battery will exhaust hydrogen while charging. Do not charge the battery at the well ventilated place. Meanwhile, flame and spark are not allowed while charging.
- The electrolyte is heavy acid solution, be sure skin and eyes do not touch it, otherwise, rinse with water immediately.

WARNING



The exhaust is poisonous, pay attention to the following:

- The exhaust is harmful to the health, do not run the engine at the confined rooms or unventilated places. If you have to run the engine indoors, be sure there is good ventilation equipment.

WARNING



Be care no to be involved:

- Do not touch the moving parts while the engine is running, meanwhile, when the engine is linked to the load, please cover the coupler and belt etc parts which have potential danger before running.

CAUTION



Be care of the hot parts:

- The muffler and the engine body will be very hot during running or just after running, do not touch these parts.

WARNING

Other safety information:

- Do not operate the engine after drinking.
- Be sure that the surrounding is safe before starting the engine.
- Put on the uniform and anti-slippery shoes.

Main Items		AHD170	AHD178	AHD186	
Type		Single-cylinder, 4-stroke, vertical, air-cooled, direct-injection diesel engine			
Combustion System		Direct injection combustion			
Bore x Stroke(mm)		70 x 57	78 x 64	86 x 72	
Piston Displacement(L)		0.219	0.305	0.418	
Rated Power	Max.kW(PS)	4.2	6.0	9.0	
	Continue.kW(PS)	3.8	5.5	8.5	
Output Shaft	Rated Speed(rpm)				
	Rotation direction	Unclockwise viewed from the output shaft			
Fuel Oil	Spray Pressure kg/cm ² (MPa)	200(19.6)			
	Applicable Fuel Oil	Light diesel			
	Fuel Tank Capacity(L)	2.5	3.5	5.5	
Lubricating System	Lubricating Method		Pressure plus splashing		
	Applicable Lube Oil		SAE 10W30 beyond CC grade		
	Lube Oil	Full(L)	0.75	1.1	1.65
	Capacity	Effective(L)	0.25	0.4	0.6
Starting System		Recoil starter or Recoil/Electric starter			
Cooling System		Forced air-cooled			

2.SAFETY LABEL LOCATION

This label guides you how to operate the engine safely.If the label comes off or becomes hard to read,contact with your agent for replacement.

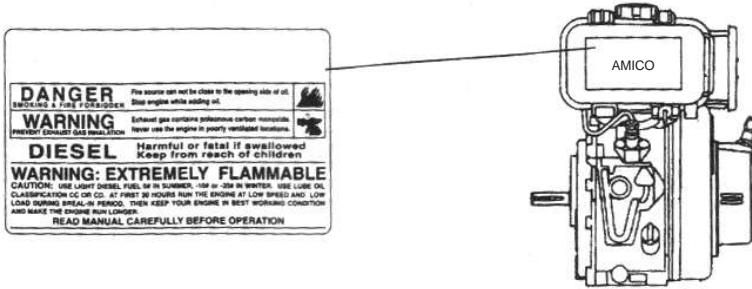

3.ASSEMBLING



[OPERATING NOTICE]

- Too much shock during the running will damage the engine and the load,be sure to set the engine tightly.

- ① Fix the engine base seat tightly to prevent the engine from offset and shock.
- ② Be sure the PTO shaft centers are in line.



CAUTION

- If the pulley is too tight,the accident will result.Please select the applicable size pulley.

- ③ If the pulley drives the engine,the pulley size must be in conformance with the load speed.

The diameter of the pulley can be calculate by the following format:

$$\text{Engine side pulley} = \frac{\text{Load side pulley} \times \text{load speed}}{\text{Engine speed}(\text{rated speed})}$$

④ Make sure that the bearing hole of the pulley, keyway size are in conformance with the PTO shaft. Otherwise the accident will result. Correctly tight the PTO shaft bolt. Do reselect the appropriate diameter pulley, if the engine continually exhaust black smoke during the running.

⑤ Be sure the pulley tension is appropriate. If the belt is too tight, hard starting will result, further more, the belt will worn quickly and the PTO shaft will be bent, so the accident will result.

The torsion of the pulley: Press the central part of the pulley surface. Every 100mm of the pulley, deflection is about 1.6mm. (For example: the clearance of the pulley is 500mm, the deflection will be 8mm.)

⑥ Specified V-belt quantity:

Model	Belt Model x Quantity,
AHD170	A type x 2
AHD178	B type x 3
AHD186	B type x 3

If you have any question about the assembling of the engine and the connection to the load, contact with your agent.

4. ENGINE USAGE

The first 20hrs are the break-in period of the engine, the operator must obey to following items:

■ Warm up the engine 5 minutes after the initial starting.

Run the engine at low speed and zero load before the engine becomes warm. Do not run the engine at high speed and zero load.

■ Do not run the engine with overload,

Recommend to run the engine at 3600r/min with 50% load in break-in period.

■ Replace the engine oil on time.

Replace the engine oil while the engine is warm after 20-hours-running, the old engine oil will be drained out completely. (Please see 8.1 Replace the Engine Oil)

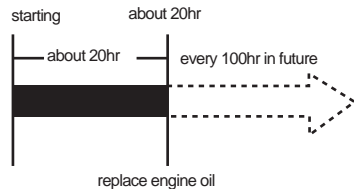

4-1 Selection and Usage of the Fuel oil

① Selection and Usage of the fuel oil

Please use the light diesel most applicable for the performance of the engine.

② Diesel usage:

- If diesel is mixed with water and dirty, the abnormal running will result. Seal the diesel in clean drums and store the drums in a dry place away from the rain and dirty.
- If diesel has been stored for several hours, the water and dirty will deposit at the bottom of the drum. You can pump the upper portion of the diesel for usage.

③ Refill the diesel

⚠ DANGER

- It is very dangerous to fill the gasoline into the diesel engine. Do identify the fuel oil type and model before refilling.
- do stop the engine before refilling.
- Wipe off the overflowed diesel.

⚠ DANGER

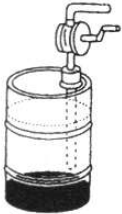

- Water and foreign matter will be sunk into the lower position in the barrel. Put the suction pipe into the barrel at the place with a half depth of the barrel, pump clean oil on the upper position in the barrel.

■ FUEL OIL CAPACITY

Model	Fuel Oil Capacity
AHD170	2.5
AHD178	3.5
AHD186	5.5

⚠ CAUTION



Do not let fuel level be higher than Red Mark

4-2 Selection and Usage of the Engine Oil

① Selection of the Engine Oil

It is very important to select the appropriate engine oil. If you use the improper diesel, the piston rings will adhere together, the piston will burn out, and the cylinder head gasket will wear out quickly as well as bearings and other moving parts like that, so the engine life will be shortened.

Recommend CC/CD oil classified by API in four seasons.

The viscosity of the engine oil is depended on the ambient temperature.

Ambient Temperature	Above 20 °C (summer)	10-20 °C (spring, fall)	Below 10 °C (winter)
	SAE 30	SAE 20	SAE 10W-30

② Check and Refill the Engine Oil



[OPERATING NOTICE]

- Check the engine oil level with the engine on a level surface and the engine stopped.
- Check the engine oil level before tightening the filler cap.

A. Be sure to check the engine oil level before starting the engine.

■ Check whether the engine oil level is between the upper level and the lower level.

■ Wipe off the overflowed engine oil.

■ Screw on the oil filler cap after checking.

B. The engine oil level can not beyond the upper level.

C. The following is the oil capacity table:

	AHD170	AHD178	AHD186
Engine Oil capacity	0.75L	1.10L	1.65L

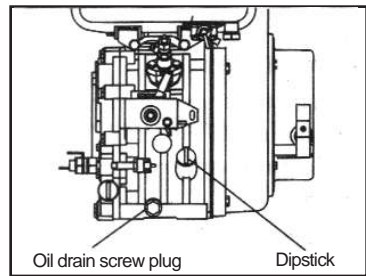
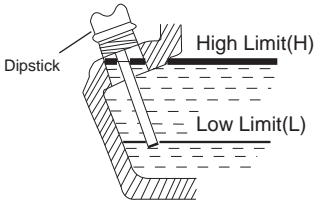

4-3 Replace the Air cleaner

- ① Screw off the wing nut and remove the air cleaner cover. If the engine is not sufficient, the exhaust color will be abnormal, then it is necessary to replace the element.

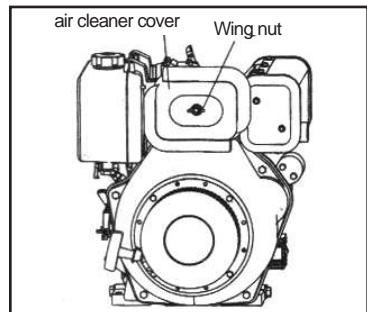

- ② Reassemble the air cleaner cover and screw on the wing nut after replacement.

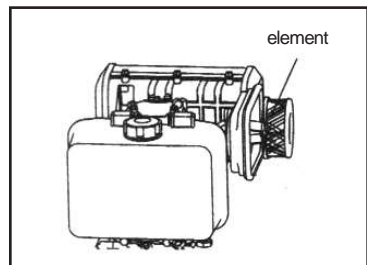

4-4 The Exhaust Direction

To prevent the exhaust from flowing into the air cleaner, assemble an exhaust syphon on the case of the muffler



NOTE

- Prevent the water from accumulating on the exhaust syphon from flowing into the muffler.

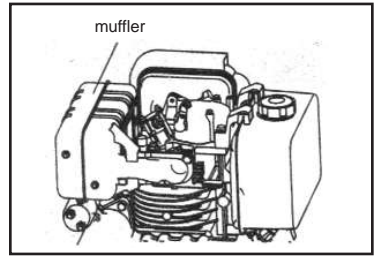

5. START THE ENGINE

5-1 Manual Starting:

- Start the engine according to the following procedures:
- ① Open the fuel cock.

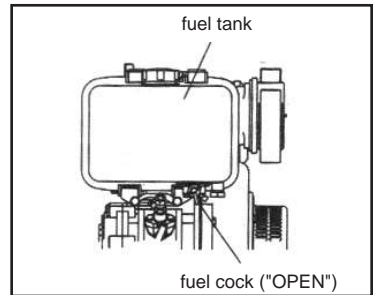

- ② Turn the governor lever to "STARTING" position

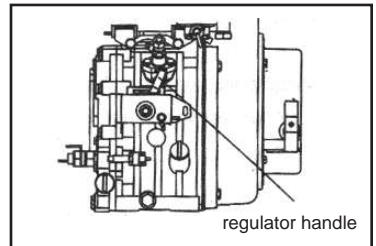

- ③ Hold the recoil starter handle
 - A. Pull the starter handle until you feel the resistance, then return the handle slowly.

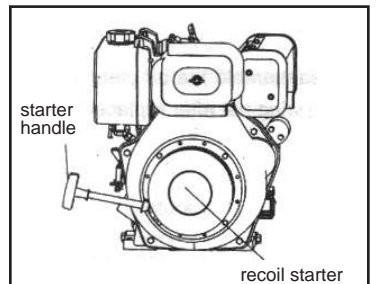

B. Press the decompression lever to "Non-compression" position. The lever will return back automatically after the engine started.

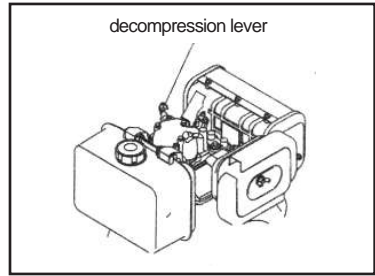

C. Hold the recoil starter handle with two hands and pull it hardly.

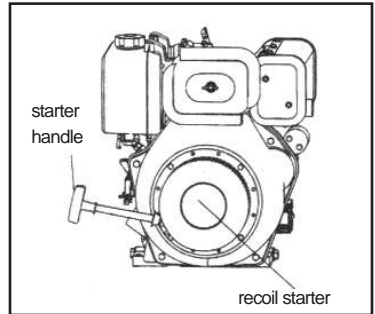

D. It is difficult to start the engine at cold weather. Remove the rubber plug on the cylinder head and fill about 2CC engine oil before starting.

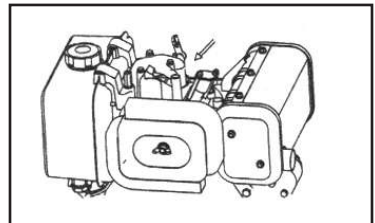

! NOTE

- Always screw on the rubber plug on the cylinder head except filling, to prevent the rain and dirty from flowing into the engine body.

START THE DIESEL ENGINE

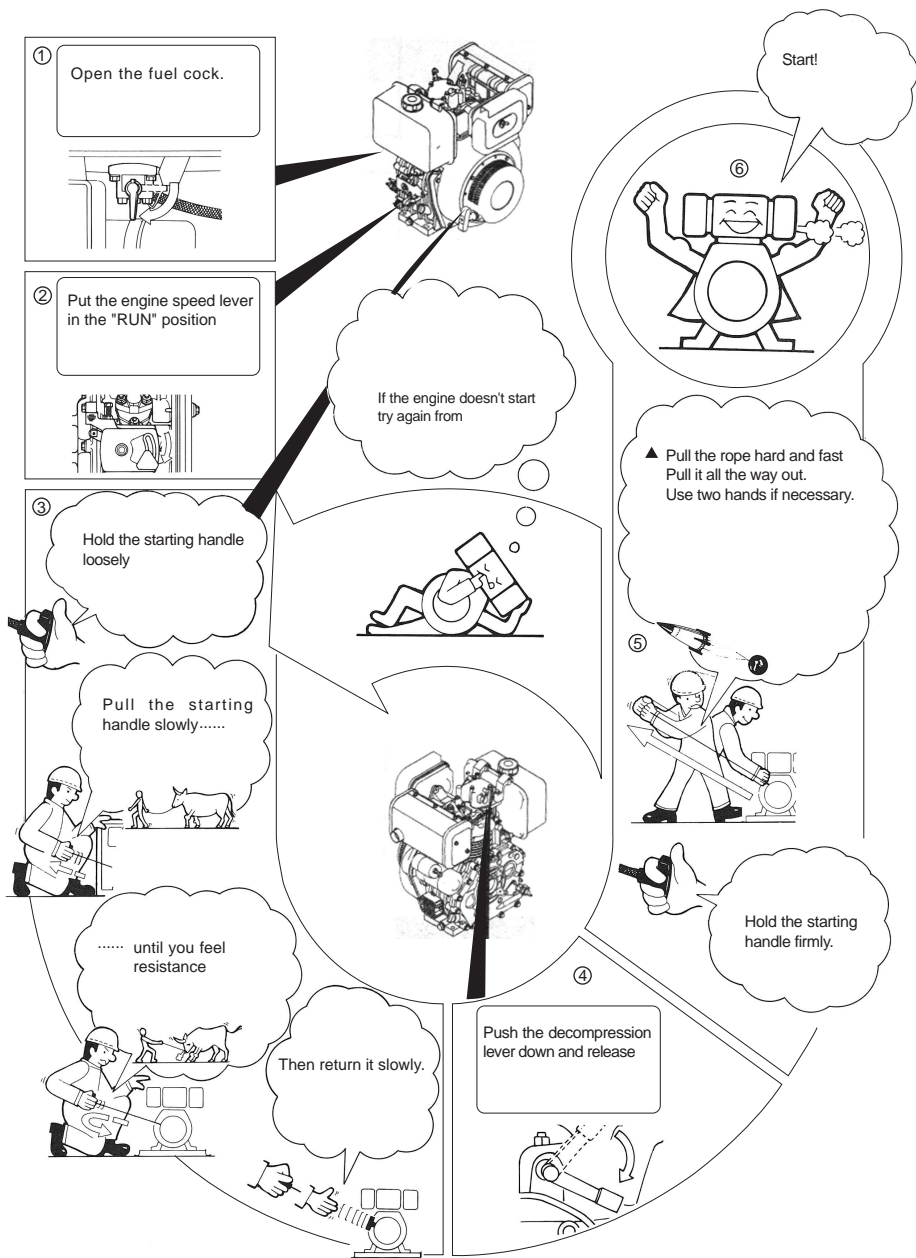

START THE DIESEL ENGINE

✘

For3, don't pull the rope too fast or hard.



○

Always pull the rope slowly.

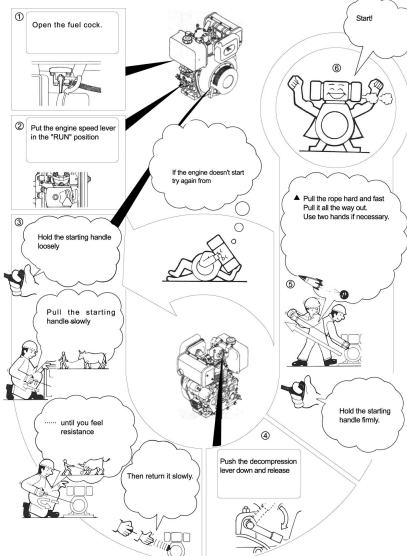
① Open the fuel cock.

② Put the engine speed lever in the "STOP" position.

③ Hold the starting handle loosely.

④ Pull the starting handle slowly.

⑤ Hold the starting handle firmly.

⑥ Push the decompression lever down and release.

⑦ Pull the rope hard and fast. Pull it all the way out. Use two hands if necessary.

If the engine doesn't start by again from.

Start!

..... until you feel resistance

Then return it slowly.

✘

For5,if you don't pull the rope all the way out ,the engine won't start



○

Always pull the rope all the way out.



✘

For5,if you don't pull hard enough,the engine won't start



○

Always pull the rope hard and fast.



5-2 Electric Starting

① Starting Method:

(Pre-starting check is same as that of manual starting.)

A. Open the fuel cock.

B. Turn the governor lever to "STARTING" position.

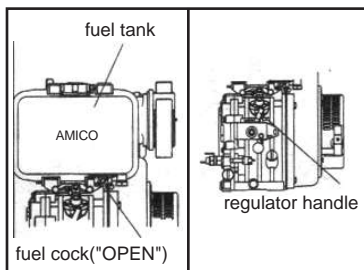

C. Turn the electric starting key clockwise to "STARTING" position.

D. Release the electric starting key after the engine is started

E. If the engine could not start after the starting motor ran ten seconds, start it again after 15 seconds. (Run the starting motor for long time will cost the battery power greatly even burn out the motor.)

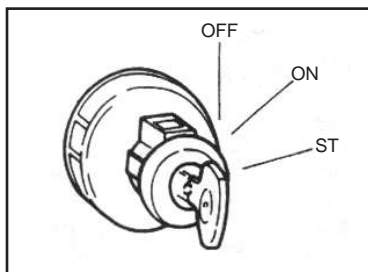

② Maintenance of the battery

A. Check the battery every month.

recommended battery size:

170/178	12V/20AH
186	12V/24AH

5-4 Assembling the Electric Starting switch

If the electric starting switch locates on the top of the cylinder head case, assemble it with the following parts according to the specified procedures:

ASSEMBLY:

NO.	Specification	Quantity
1	Electric starting switch body	1
2	Electric starting switch panel	1
3	Long washer	2
4	Hexagonal bolt M6 x 70	2

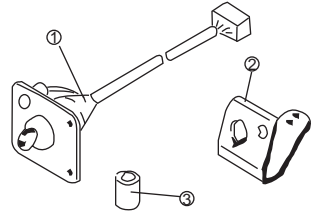

PROCEDURES:

- ① Remove the electric starting switch body from the standard panel, then reassemble it to the installation panel of the cylinder head case.
- ② Screw off the two bolts from the cylinder head case.
- ③ Clip the reassembled panel with the long washer, then tight it with hexagonal bolts.

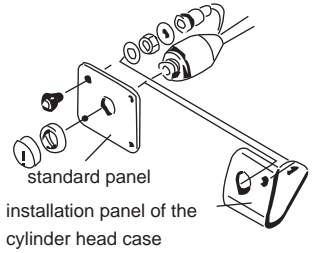

 **[OPERATING NOTICE]**

■ If the wire harness touch the muffler or the PTO shaft, the fire will result.

- ④ Set the earth terminal of the harness with M6 bolt.

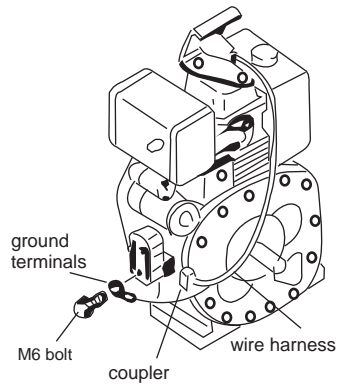
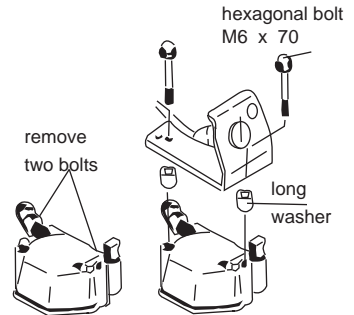

ELECTRIC WIRING DIAGRAM

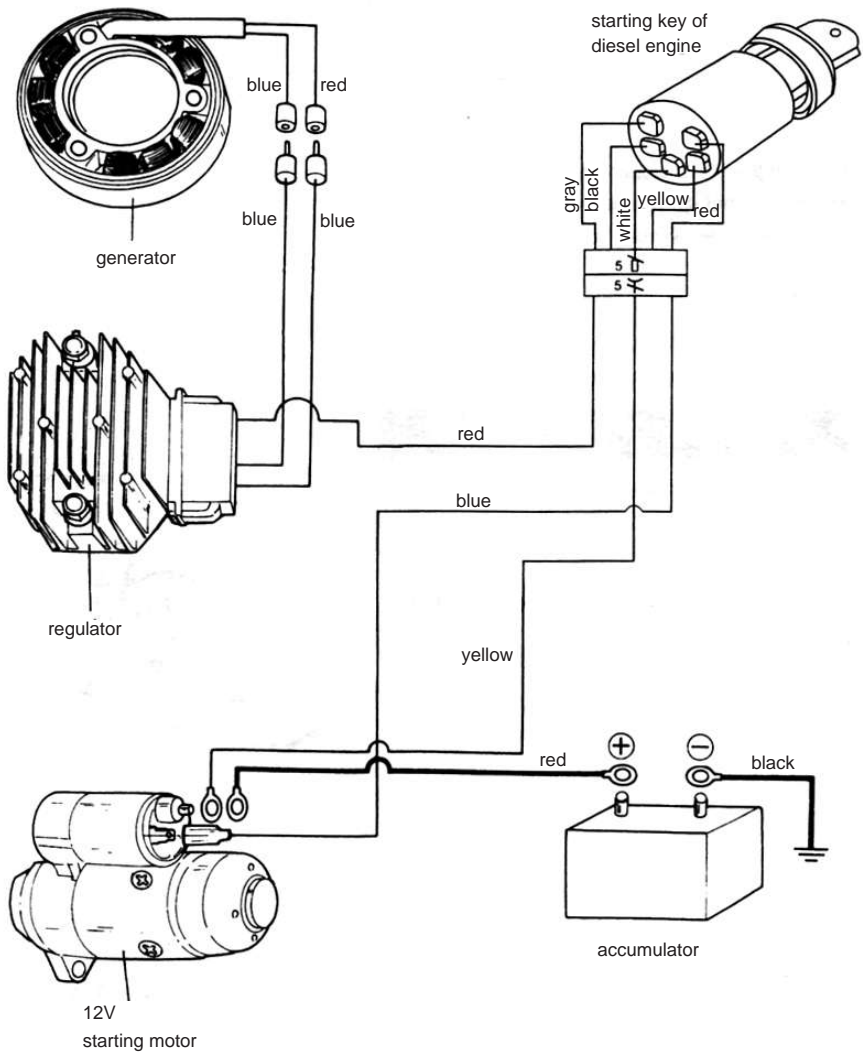

6.Run the Engine

WARNING

- To prevent the exhaust toxication, be sure to run the engine at ventilated place.
- To prevent personal injury, avoid hands, personal body and cloths from involving into the output shaft, pulley and V pulley etc moving parts.
- Check the moving parts and the surrounding parts after stop the engine. Be sure that there is no tool or cloth inside the engine body.

CAUTION

- The muffler is very hot during running or just after running, do not touch the muffler.
- The air cleaner will suck the surrounding airflow during the running. To prevent the injury, avoid hands, personal body and cloths approach this part.

- ① Warm up the engine for 5 minutes.
- ② If the engine is very hot, set the governor lever to the expected position.

NOTE

- Be sure to regulate the engine speed with the governor lever.

NOTE

- Do not screw off the adjusting bolt and the fuel adjusting bolts, otherwise the abnormal speed and output will result.

- ③ If the engine continually exhaust black smoke during running, which indicates that the engine is running with overload, do adjust the engine pulley and the load pulley.

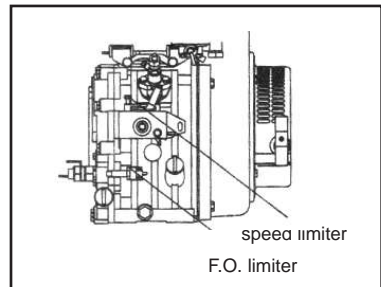

◎ PLEASE PAY ATTENTION TO THE FOLLOWING ITEMS WHILE RUNNING:

- ① Whether there is abnormal vibration and sound.
Whether the exhaust is normal.
- ② Whether the engine continually exhausts white smoke or black smoke.
- ③ Be sure to shut off the engine when the abnormal phenomenon arouses, and contact with agent.

7.STOP THE ENGINE



[OPERATING NOTICE]

■ If the engine is stopped in emergency, the engine temperature will rise quickly, thus the engine life will be shortened.

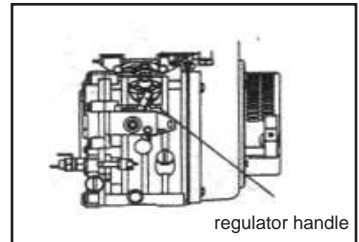

regulator handle

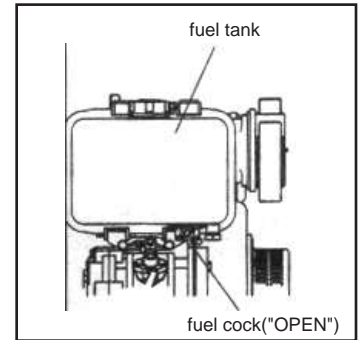

fuel cock("OPEN")

- ① Set the governor lever to the low speed position, then run the engine at zero load five minutes.
- ② Set the governor lever to the *STOP* position. Do not stop the engine with the decompression lever.
- ③ Set the fuel cock to *OFF* position.
- ④ Pull the recoil starter handle slowly, until you feel resistance. (At this point, the decompression just begins and intake/exhaust valves are both closed, thus the cylinder can be prevented from rust.)
- ⑤ Concerning the electric starting engine, directly turn the starting key to *OFF* position.

◎ PREPARE FOR THE NEXT OPERATION:

- ① Fill diesel to the tank.
- ② Check all the bolts and nuts. Screw on them if necessary.
- ③ Clean the dirty on the surface of the engine body.

8.Periodical Check and Maintenance

Periodical Check and maintenance are very important for maintaining the performance and life of the engine.The following is the maintenance intervals and items table.The item with "-" require technician or special tools,please contact with agent.Periodical check and maintenance table:

Intervals Items	every day	20hrs	50hrs	100hrs	200hrs	500hrs	1000hrs
	Check all the bolts and nuts	○					
Check and refill engine oil	○						
Replace engine oil		○ (First time)	○ (Second time)				
Clean or replace engine oil cleaner		○ (Clean)	○ (Clean)				○ (Replace)
Check oil leakage	○						
Replace air cleaner						○	
Clean fuel oil cleaner				○		○	○ (Replace)
Check nozzle						●	
Check fuel injection pump						●	
Adjust the clearance of the intake/exhaust valve						●	
Check the intake/exhaust valve							●
Replace the piston ring							●
Check the electrolyte	Check it every month,refill the distilled water if necessary.						

Replace Engine Oil

Drain out the engine oil while the engine is warm and refill the recommended engine oil.

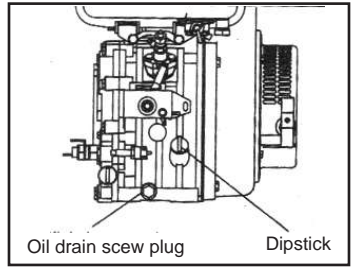

Ambient temperature	Grade	Viscosity
Above 20 C (Summer)	Beyond CC grade	SAE 30
10 C~20 C (Spring and fall)		SAE20
Below 10 C (Winter)		SAE10W-30

Replace Engine Oil	Intervals
First time	20 hrs
Second time	Every 100 hrs

Clean Engine Oil Cleaner

Screw off the bolt and take out the engine oil cleaner

Clean	Every 100 hrs
Replace	Every 1000hrs

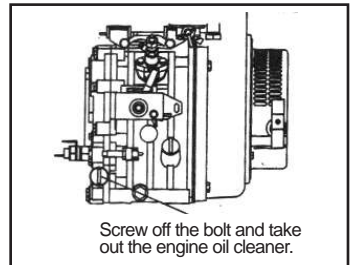

Screw off the bolt and take out the engine oil cleaner.

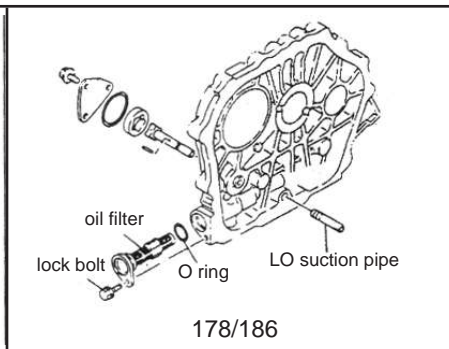
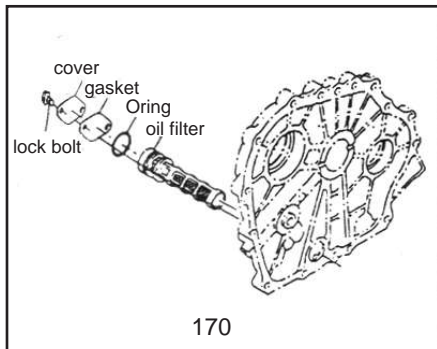

① Replace the air cleaner

A. Paper element:

Replace the element every 500 hrs.

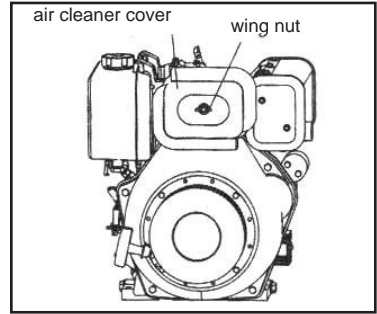

CAUTION

- If the element is too dirty, the air flow will be blocked and starting will be hard, thus insufficient output will result, further more, it will cost both fuel oil and engine oil, the engine will exhaust black smoke.
- Running engine with worn element or without element is not allowed.

B. Oil-soak Type Element

Check the engine oil level before run the engine.

- ② Refill the engine oil until the upper level. Replace if it is too dirty. Often clean the element with kerosene, then soak it in the engine oil and squeeze out the excess engine oil.

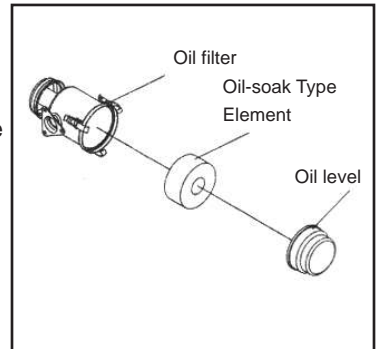

④ Clean the Fuel Oil Cleaner

Remove the fuel oil cleaner from the tank and clean it on time.

Clean	Every 500 hrs
Replace	Every 1000 hrs

A. Completely drain out the fuel oil.

B. Screw off two nuts of the fuel cock and take out the fuel oil cleaner.

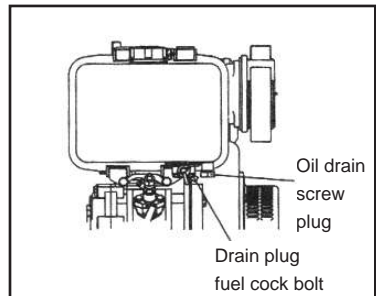

- ⑤ Screw on the bolts on the cylinder head. This operation requires special tools, please contact with your agent.

- ⑥ The adjustment of fuel nozzle and fuel injection pump and the replacement of the valve seats, parts require special technology, please contact with your agent.
- ⑦ Check the battery every month.

9.LONG-TERM STORAGE

Prepare the following items before long-term storage:

- ① Run the engine five minutes at low speed.
- ② Drain out the engine oil while the engine is warm and refill the fresh engine oil.
- ③ Remove the filler screw plug on the cylinder head case and refill about 2cc engine oil.
- ④ Press down the decompression lever and pull the recoil starter 2-3 times(Do not start the engine)
- ⑤ Return the decompression lever back to the decompression position, and pull the recoil starter slowly until you feel the resistance.(At this point, both intake/exhaust valves are closed to prevent the engine from rust.)
- ⑥ Clean off the dirty on the engine surface, then store the engine at the dry place.

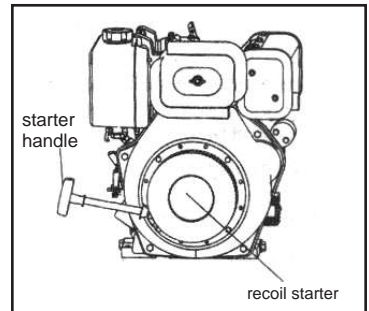
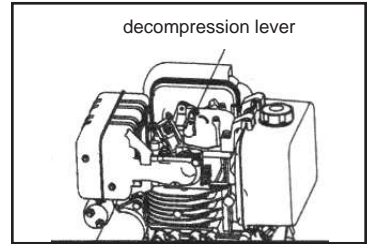
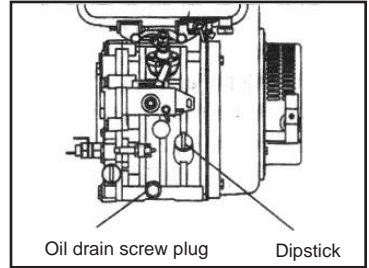

10.DETAIL DIAGRAM

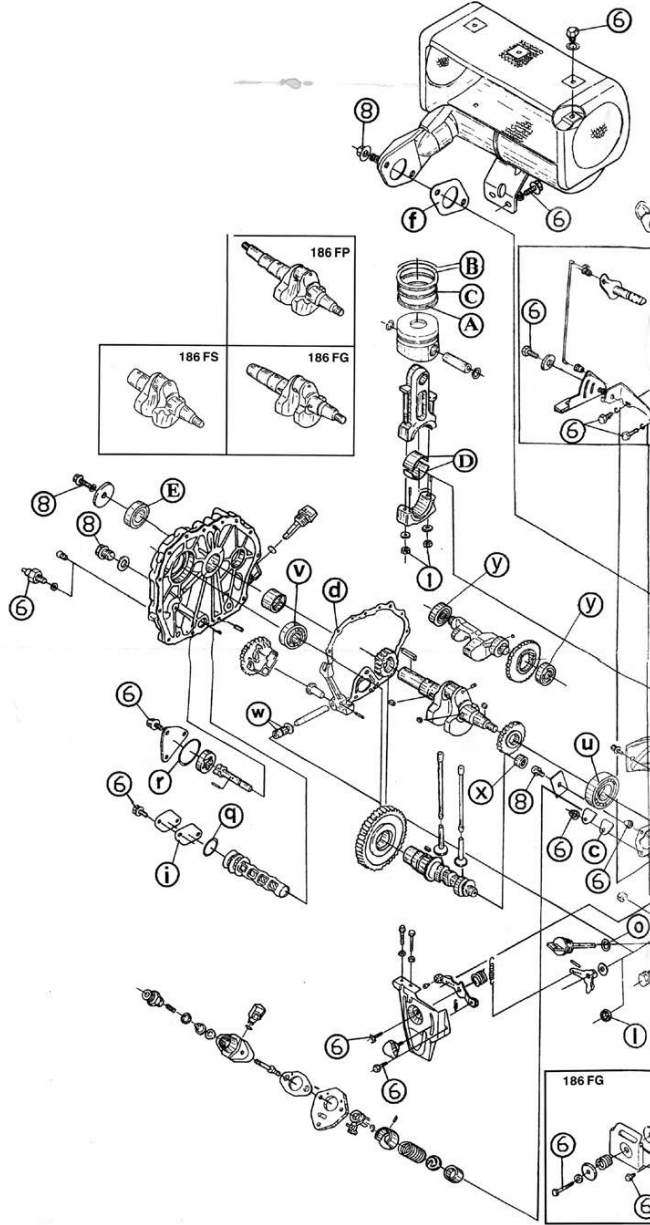

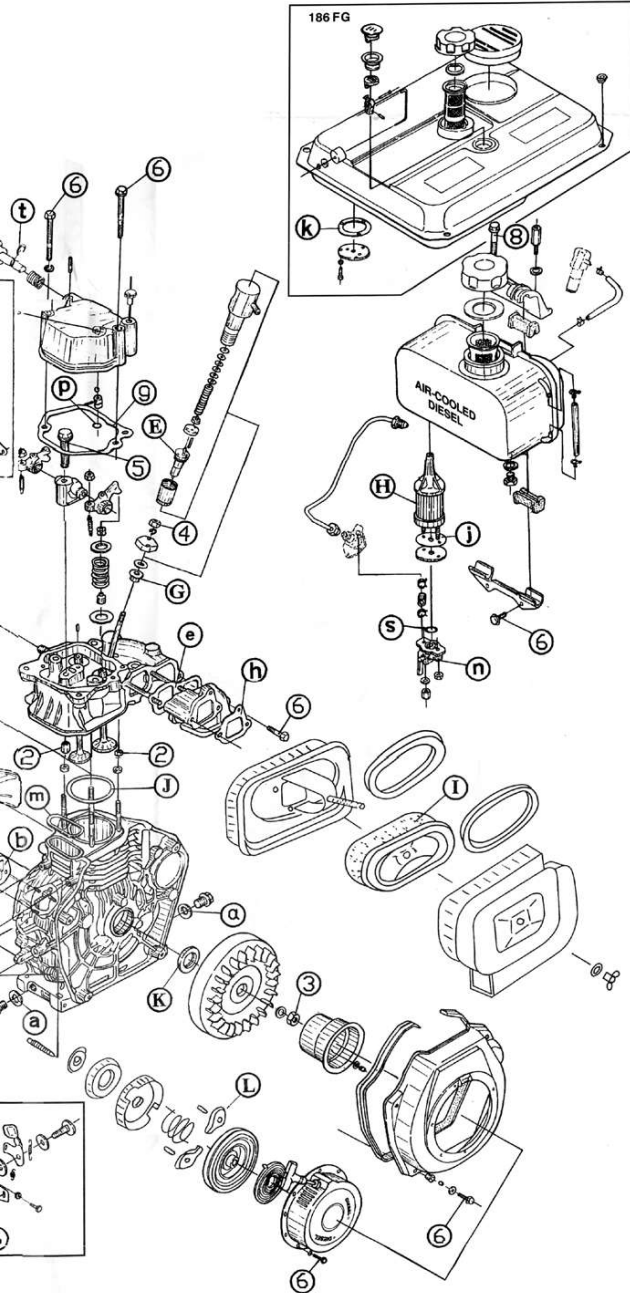

CAUTION

- Do not wash the air cleaner element with detergent
- Replacement cycle is every 500 hours
- Replace when output decreases or bad exhaust color is noticed

AIR-COOLED DIESEL



HOW TO START

- Open fuel tank. Pull the lever in the "OFF" position.
- Push the starting handle slowly.
- Push the stop handle to the "STOP" position & release.
- Push the decompression lever down and release.
- After the engine starts, turn the stop handle to the "ON" position.

CAUTION

FUEL OIL

- USE DIESEL FUEL
- CLEAN FILTER EVERY 300hrs.

LUBE OIL

- USE 10WV GRADE / C.C.
- CHANGE LUBE OIL EVERY 100hrs.
- CLEAN FILTER EVERY 100hrs.

STARTING

- CHECK LUBE OIL LEVEL
- NO FUEL
- FOR EASY STARTING IN COLD
- WARM UP WITHOUT LOAD.

STOPPING

- CLOSE FUEL COCK.
- AFTER STOPPING ENGINE.

WARNING

- Use light diesel fuel No.0 in summer, No.10 or No.20 in winter.
- The engine must be used lube oil GRADE CC or CD.
- At first 20 hours run the engine at low speed and low load to keep your engine in best working condition and make it run longer.
- Please read the operation manual before running the engine.

100 Air-Cooled Diesel

Max Output	6.3kW	8.5kW
Cont Output	5.7kW	8.3kW
Engine Speed	3000rpm	3600rpm
Displacement	0.606L	
Serial No.		

Ref No.	Part No.	Description	Qty.
1	186F ~ 18003	Trade Marks Tag I	1
2	186F ~ 18004	Start Operation Tag	1
3	186F ~ 18005	Caution Tag	1
4	186F ~ 18007	Model Tag	1
5	186F ~ 18009	Warning Tag	1
6	186F ~ 18012	Air Cleaner Tag	1
7	186F ~ 18013	Air Cooled Diesel Engine Tag	1

Unit:N. m

Ref No.	Description	Torque
①	Rod Bolt Nut	40~45
②	Cyl Head Nut	54-58
③	Flywheel Nut	120~135
④	Nozzle Retainer Nut	8 ~10
⑤	Rocker Arm Tighten Stud	20~22
⑥	Bolt M6 (Nut)	10~12
⑦	Bolt M8 (Nut)	18~22 I

Full Gasket Sets

Ref No.	Part No.	Description	Qty.
a	186F-01100	Oil Plug Gasket Assem.	2
b	186F-10017	Fuel Injection Pump Shim Set	1
c	186F-10016	Seal Gasket	1
d	186F-01015	Crank Case Gasket	1
e	186F-02014	Air Intake Gasket	1
f	186F-02015	Exhaust Gasket	1
g	186F-03003	Bonnet Gasket	1
h	186F-07001	Air Cleaner Gasket	1
i	186F-09002	Oil Filter Plate Gasket	1
J	186F-10007	Fuel Oil Filter Gasket	1
k	186F-10013	Connecting Plate Gasket	1

Rings

Ref No.	Part No.	Description	Qty.
m	186F-01007	O-RingZ	1
n	GB3452.1-92	O-Ring 11 x 1.9G	1
o	GB3452.1-92	O-Ring 24 x 2.4G	2
P	GB3452.1-92	O-Ring 10 x 1.9G	1
q	GB3452.1-92	O-Ring 25 x 2.4G	1
r	GB3452.1-92	O-Ring 34.5 x 1.8G	1
s	GB3452.1-92	O-Ring 13.2 x 1.9G	1
t	GB3452.1-92	O-Ring 12 x 1.8G	1

Full Gasket Sets

Ref No.	Part No.	Description	Qty.
1	186F-11008	Lever shaft Seal	1

Bearings

Ref No.	Part No.	Description	Qty.
u	GB ! T276-94	Ball Bearing 6308/P5	1
v	GB/T276-94	Ball Bearing 6207/P5	1
w	GB290-89	Needle Bearing HK081210	2
x	GB290- 89	Needle Bearing HK1512	1
Y	GB / T276- 94	Ball Bearing 6203	2

Easy Worn Parts

Ref No.	Part(Type) No.	Description	Qty.	Mounted to
A	186F-04100	Oil Ring Set	1	(4)Piston & Connecting Rod Assem.
B	186F-04001	First Gas Ring	1	(4)Piston & Connecting Rod Assem.
C	186F-04002	Second Gas Ring	1	(4)Piston & Connecting Rod Assem.
D	186F-04005	Crank Pin Bearing	2	(4)Piston & Connecting Rod Assem.
E	GB9877 ~ 1-88	Oil Seal B355010D	1	(1)Cylinder Block Assem.
F	11.433 ~ 172.001	Nozzle	1	(13)Fuel Nozzle Assem.
G	186F-02007	Spacer	1	(2)Cylinder Head Assem.
H	186F-t0300	Filter Element Assem.	1	(1)Fuel Tank & Pipe Assem.
I	186F-07100	Air Cleaner Element Assem.	1	(7)Air Cleaner Assem.
J	186F-0t012	Cyl. Head Gasket	1	(1)Cylinder Block Assem.
K	GB9877 ~ 1-88	Oil Seal B355008D	1	(1)Cylinder Block Assem.
L	186F-14008	Starter Ratchet	1	(14)Recoil Starter Assem.

(1)Cylinder Block Assembly

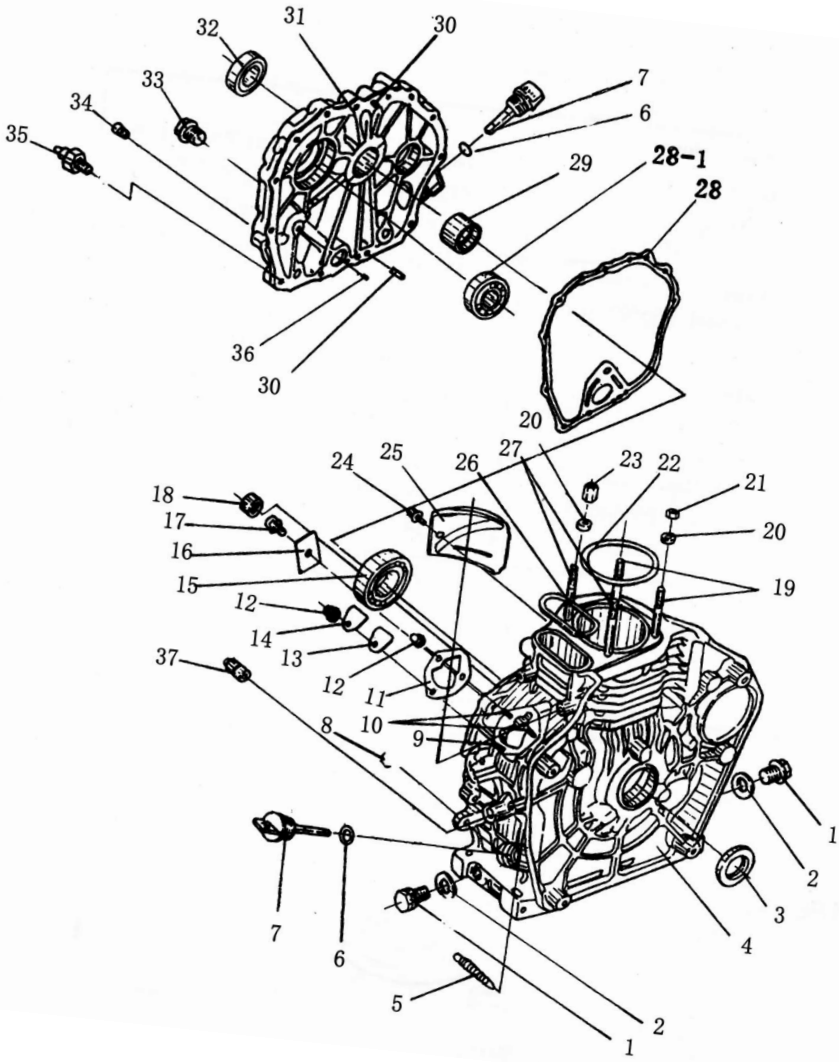

Ref No.	Part No.	Description	Qty.
1	186F-01017	Drain Plug	2
2	186F-01100	Oil Plug Seal Assem.	2
3	GB9877.1-88	Oil Seal B355010D	1
4	186F-01001	Cylinder Block	1
5	186F-11200	Fuel Controller Assem.	1
6	GB3452.1-92	O-Ring 24 x 2.4	2
7	186F-01002	Oil Depth Gauge	2
8	GB6173-86	Nut M10 x 1.25	1
9	186F-01012	Tighten Stud(Short)	1
10	186F-01001	Tighten Stud(Long)	2
11	186F-10017	Shim Set	2
12	GB6170-86	Nut M6	3
13	186F-10016	Seal Gasket	1
14	186F-10015	Seal Plate	1
15	GB/T276-94	Ball Bearing 6308	1
16	186F-01009	Retainer	1
17	GB5783-86	Bolt M8 x 12	1
18	GB290-89	Needle Bearing HK152015	1
19	186F-01003	Cylinder Head Bolt(Short)	2
20	186F-01005	Washer	4
21	186F-01004	Cyl. Head Nut(Short)	2
22	186F-01013	Cyl. Head Gasket	1
23	186F-01007	Cyl.Head Nut(Long)	2
24	GB5787-86	Bolt M6 x 20	2
25	186F-01211	Air Cover	1
26	186F-01008	O-Ring	1
27	186F-01006	Cyl.head Bolt(Long)	2
28	186F-01015	Crank Case Gasket	1
28-1	GB/T276-94	Ball Bearing 6207-P5	1
29	186F-01014	Main Bearing	1
30	GB 119-86	Pin8 x 10	2
31	186F-01016	Crank Case Cover	1
32	GB9877.1-88	Oil Seal B355008D	1
33	GB5787-86	Bolt M8 x 30	2
34	186F-01019	Plug	1
35	GB5787-86	Bolt M8 x 33.5	13
36	186F-01021	Plunger	3
37	GB290-89	Needle Bearing HK081210	1

(2)Cylinder Head Assembly

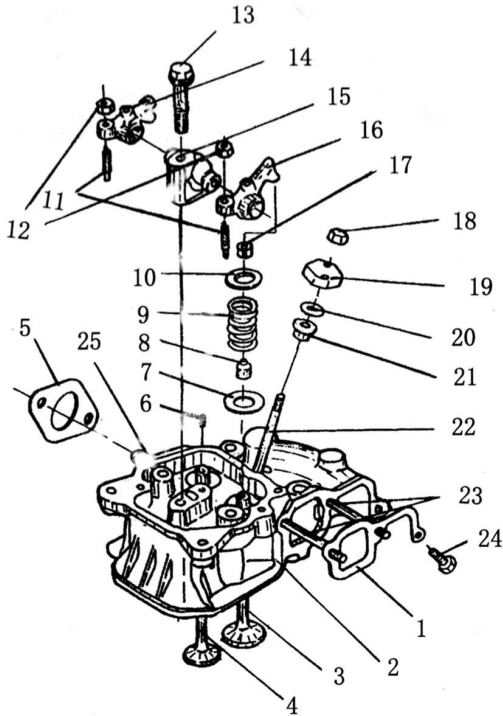

Ref No.	Part No.	Description	Qty.
1	186F-02014	Air Intake Gasket	1
2	186F-02202	Cylinder Head	1
3	186F- 02003	Intake Valve	1
4	186F-02004	Exhaust Valve	1
5	186F-02015	Exhaust Gasket	1
6	GB119-86	Pin B4 x 8	1
7	186F-02007	Washer	2
8	186F-02019	Valve duct Seal	2
9	186F-02005	Valve Spring	2
10	186F- 02002	Valve Spring Retainer	2
11	186F-02008	Valve Screw	2
12	GB6177-88	Nut M6	2
13	186F-02017	Rocker Arm Screw	1
14	186F-02012	Exhaust Valve Rocker Arm	1
15	186F-02006	Rocker Arm Support	1
16	186F-02013	Intake Valve Rocker Arm	1
17	186F-02001	Cotter	4
18	GB6177-88	Nut M6	2
19	186F-02009	Nozzle Retainer	1
20	186F-02018	Spacer Washer	1
21	186F-02011	Spacer	1
22	GB900-88	StudAM6 x 50	2
23	GB900-88	Stud AM6 x 75	2
24	GB5787-86	Bolt AM6 x 25	3
25	GB899-88	Stud AM8 x 20	2

(3)Cyl. Head Bonnet Assembly

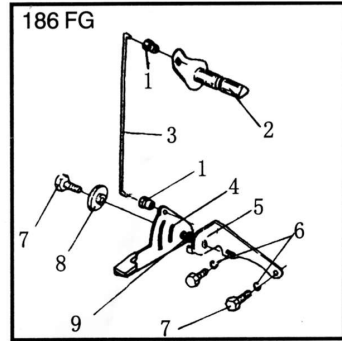
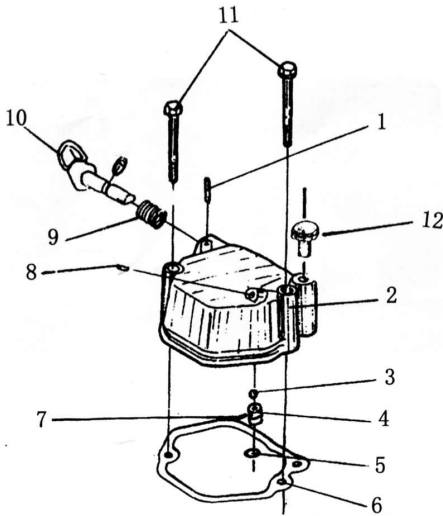

Ref No.	Part No.	Description	Qty.
1	GB119-86	Pin B3 x 16	1
2	186F-03001	Cyl. Head Bonnet	1
3	186F-03006	Ball	1
4	186F-03007	Breather Seat	1
5	GB3452.1-92	O-Ring2 x 1.9	1
6	186F-03003	Bonnet Gasket	1
7	186F-03014	Pin	1
8	186F-03015	Plunger8	1
9	186F-03004	Decompression Spring	1
10	GB3452.1-92	O-Ring2 x 1.9	1
11	186F-03100	Decompression Shaft Assem.	1
12	GB5787-86	Blot M6 x 70	2
13	186F-03016	Oiling Screw Plug	1
186FG			
1	186FG-03012	Decompression Wire Collar	2
2	186FG-03100	Decompression Shaft Assem	1
3	186FG-03011	Decompression Wire	1
4	186FG-03009	Outer Decompression Handle	1
5	186FG-03008	Decompression Handle Support	1
6	GB97.1-85	Washer6	2
7	GB5783-86	Bolt M6 x 15	3
8	186FG-03013	Outer Decompression Handle Bushin	2
9	GB3452.1-92	O-Ring2 x 1.9	1
10	GB6170-86	Nut M6	1

(4)Piston & Connecting Rod Assembly

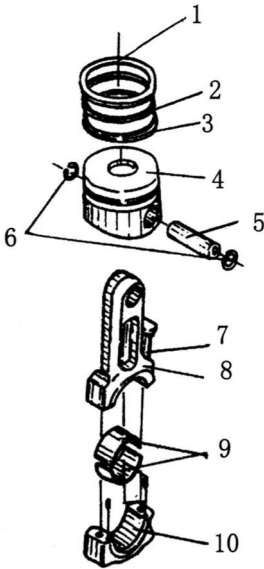

Ref No.	Part No.	Description	Qty.
1	186F-04100	Oil Ring Set	1
2	186F-04001	First Gas Ring	1
3	186F-04002	Second Gas Ring	1
4	186F-04003	Piston	1
5	186F-04004	Piston Pin	1
6	GB893.1-86	Washer 23	2
7	186F- 04008	Rod Bolt	2
8	186F-04007	Connecting Rod Body	1
9	186F-04005	Crank Pin Bearing	2
10	186F-04006	Crank Pin Box	1

(5)Fuel Nozzle Assembly

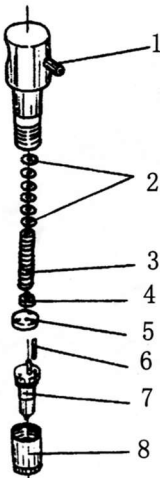

Ref No.	Part No.	Description	Qty.
1	11-435-127-003	Nozzle Holder Assem.	1
2	11-430-100-240	Shim Pack	1
3	11-430-613-001	Nozzle Spring	1
4	11-433-120-000	Spring Retainer	1
5	11-430-136-000	Stop Plate	1
6	11-433-261-004	Pin	2
7	11-433-172-001	Nozzle Valve	1
8	11-433-314-009	Nozzle Case Nut	1

(6)Crank Shaft & Flywheel Assembly

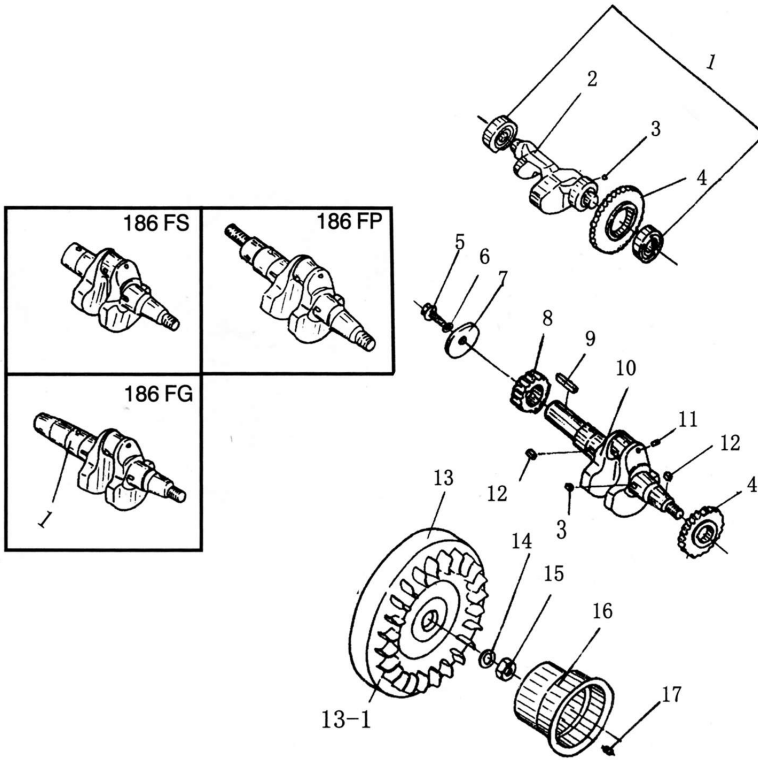

Ref No.	Part No.	Description	Qty.
1	GB / T276-94	Ball Bearing 6203/P5	2
2	186F-05301	Balancer Shaft	1
3	186F - 05006	Key	2
4	186F - 05004	Balancer Gear	2
5	186F-05007	Output End Tighten Stud	1
6	GB93-87	Washer10	1
7	186F-05005	Output End Washer	1
8	186F-05203	Crank Shaft Timing Gear	1
9	GB1096-79	Key6 x 50	1
10	186F-05201	Crank Shaft	1
11	186F-05202	Plunger6	1
12	GB1096-79	Key5 x 12	1
12-1	GB1096-79	Key5 x 14	1
13	186F-05101	Flywheel	1
14	186F-05003	Flywheel Nut Washer	1
15	186F-05002	Flywheel Nut	1
16	186F-05001	Starter Pulley	1
17	GB5787-86	Bolt M6 x 12	3
	186FG- 05006	Crank Shaft	1

(7) Air Cleaner Assembly

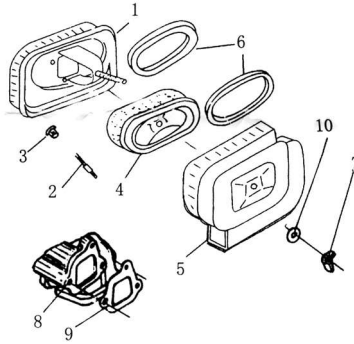

Ref No.	Part No.	Description	Qty.
1	186F-07300	Air Cleaner Bottom Case Assem.	1
2	186F-07301	Bolt	1
3	GB6177-86	Wing Nut M6	3
4	186F-07100	Air Cleaner Element Assem.	1
5	186F-07200	Air Cleaner Cover Assem.	1
6	186F-07203	Shockproof Sealing Assem.	2
7	GB62-88	Nut M8	1
8	186F-07401	Intake Pipe	1
9	186F-07001	Air Cleaner Gasket	1
10	GB97.1-85	Washer	1

(8) Camshaft Assembly

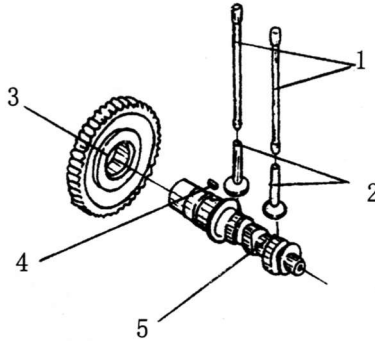

Ref No.	Part No.	Description	Qty.
1	186F-06100	Valve Rod Assem.	2
2	186F-06003	Valve Tappet	2
3	186F-06002	Camshaft Timing Gear	1
4	GB 1096-79	Key 5 x 12	1
5	186F-06001	Camshaft	1

(9) Silencer Assembly

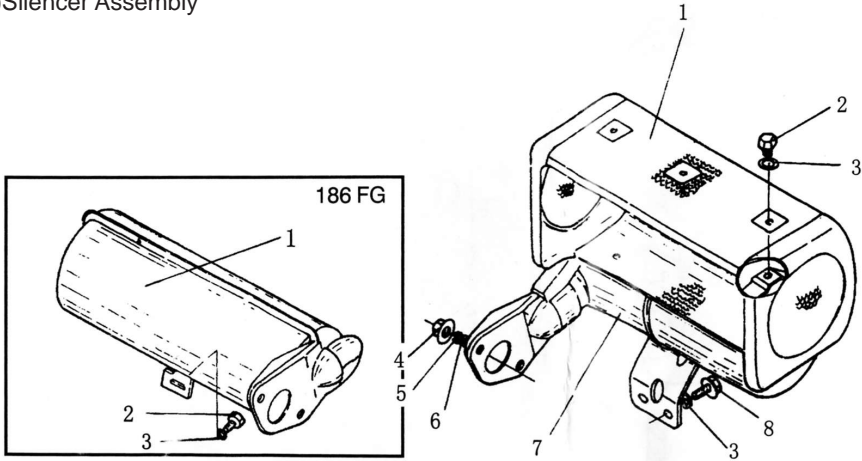

Ref No.	Part No.	Description	Qty.
1	186F- 08100	Case Welded Assem.	1
2	GB5787-86	Bolt M6 x 8	6
3	GB97.1-85	Gasket 6	8
4	GB6170-86	Nut M8	2
5	GB859-87	Washer8	2
6	GB97.1-85 -	Gasket 8 --	2
7	186F- 08200	Silencer Welded Assem.	1
8	GB5787-86	Bolt M6 - 12	2
186FG			
1	186FG- 08000	Silencer Assembly	1
2	GB5783-86	Bolt M8 x 15	1
3	GB97.1-85	Washer 8	1

(10) Lube Oil System

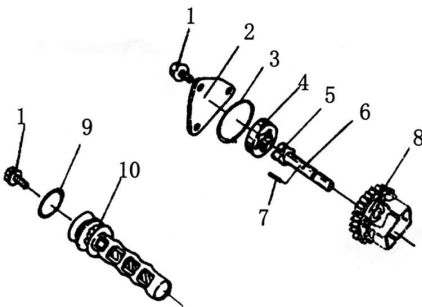

Ref No.	Part No.	Description	Qty.
1	GB5787-86	Bolt M6 x 12	3
1-1	GB5787-86	Bolt H6 x 14	1
2	186F- 09001	Oil Pump Butt Plate	1
3	GB3452.1-92	O-Ring34.5 x 1.8	1
4	186F-09101	Inner Rotator	1
5	186F- 09103	Outer Rotator	1
6	186F- 09102	Oil Pump shaft	1
7	GB 119-86	Pin B3 x 16	1
8	186F- 09002	Oil Pump Gear	1
9	GB3452.1-92	O-Ring25 x 2.4	1
10	186F- 09200	Oil Filter Assem.	1

(11) Fuel Tank Fuel Pipe Assembly

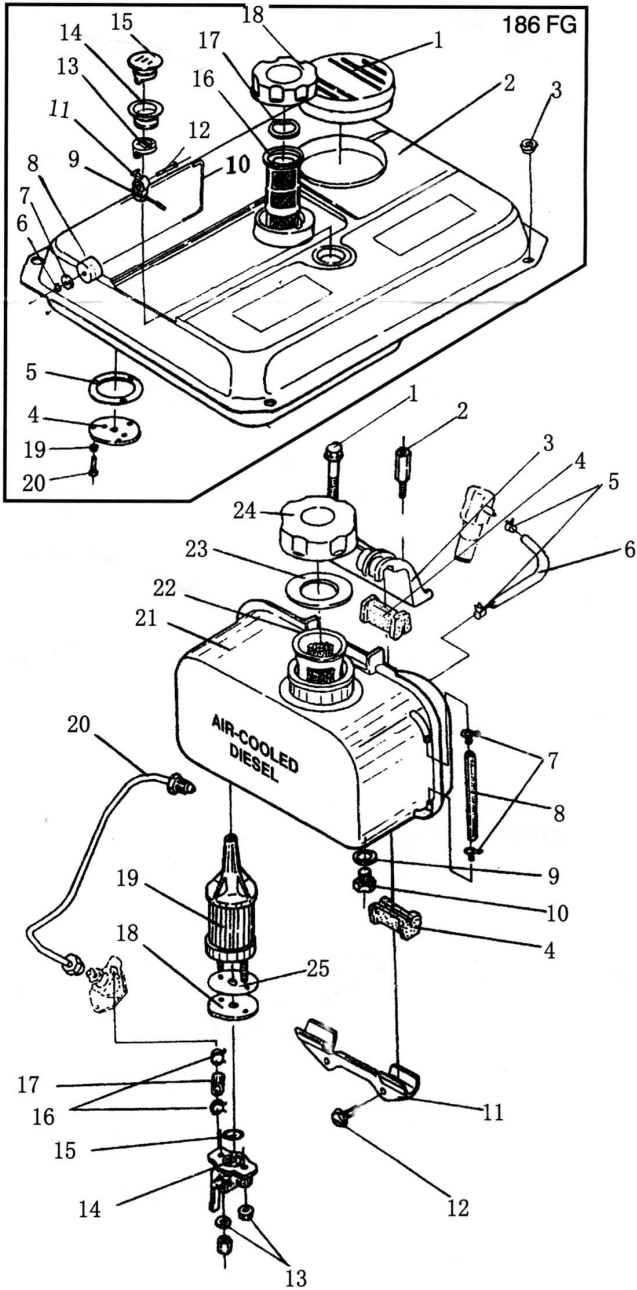

Ref No.	Part No.	Description	Qty.
1	GB5787-86	BoltM8 x 50	1
2	186F- 10003	Bolt	1
3	186F- 10001	Upper Stay	1
4	186F- 10002	Damper	4
5	186F- 10013	Clamp	2
6	186F- 10012	Fuel Oil Return Pipe	1
7	186F- 10005	Clamp	1
8	186F- 10006	Gauge Pipe	1
9	186F- 10008	washer	1
10	GB5786-86	BoltM12 x 1.25x 14	1
11	186F- 10600	Lower Stay Assem.	1
12	GB5787-86	BoltM6 ~ 14	2
13	GB6177-86	Nut M6	2
14	186F- 10400	Fuel Tank CockAssem.	1
15	GB3452-92	O-Ringl3.2 x 1.8	1
16	186F- 10011	Clamp	2
17	186F- 10009	Fuel Oil Pipe	1
18	186F- 10007	Fuel Oil Filter Gasket	1
19	186F- 10300	Filter Element Assem.	1
20	186F- 10500	Fuel Injection Pipe Assem	1. 1
21	186F- 10200	Fuel Tank Welded Assem.	1
22	186F- 10004	Fuel Oil Filter	1
23	186F- 10102	Gasket	1
24	186F- 10100	Fuel Tank Cap Assem.	1
186FG			1
1	186FG- 10003	Adjusting Hole Cover	1
2	186FG- 10200	Fuel Tank Welded Assem.	4
3	186FG- 10004	Fuel Tank Damper	1
4	186FG- 10011	Connecting Plate	1
5	186FG- 10012	Connecting Plate Gasket	1
6	186FG- 10607	Circlip	1
7	GB97.1-85	Washer 2	1
8	186FG- 10601	Floater	2
9	GB869-76	Rivet 3 x 5	1
10	186FG- 10602	Swing Bar	1
11	186FG- 1060:	Fuel Indicator	1
12	GB869-76	Rivet 2.5 x 24	1
13	186FG- 10604	Pointer Support	1
14	186FG- 10606	Sealing Bush	1
15	186FG- 10605	Pointer Window Support	1
16	186FG- 10001	Filter Cup	1
17	186FG- 10002	Filter Cup Supporting Ring	1
18	186FG- 10100	Fuel Tank Cap Assem.	3
19	GB97.1-85	Washer 5	3
20	GB5786-86	Bolt M5 x 14	

(12)Fuel Injection Pump Assembly

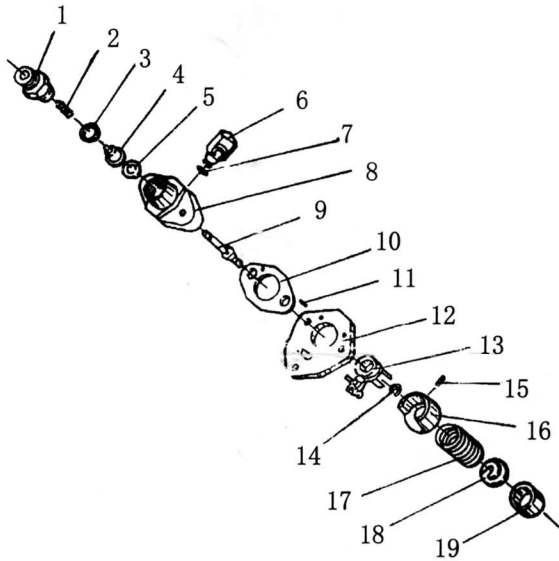

Ref No.	Part No.	Description	Qty.
1	11-413-372-001	Delivery Holder	1
2	11-414-628-001	Delivery Spring	1
3	11-410-100-005	Delivery Seal Gasket	1
4	11-418-502-108	Delivery Valve Core	1
5	11-418-600-203	Delivery Seat	1
6	11-413-373-001	Joint	1
7	11-400-210-004	O-Ring	1
8	11-415-101-001	F.I. Pump Body	1
9	11-418-205-501	Plunger	1
10	11-410-050-001	Shim Set	
11	GB879-86	Pin2 x 6	2
12	11-415-700-004	Packing	1
13	11-410-326-003	Oil Control Muff Welded Assem.	1
14	11-410-224-001	Steel Wire Retainer	1
15	GB879-86	Pin3 x 8	1
16	11-410-506-001	Spring Seat	2
17	11-414-633-001	Plug Spring	1
18	11-410-330-003	Spring Seat	1
19	11-418-731-001	Tappet	1

(13)Governor & Control System

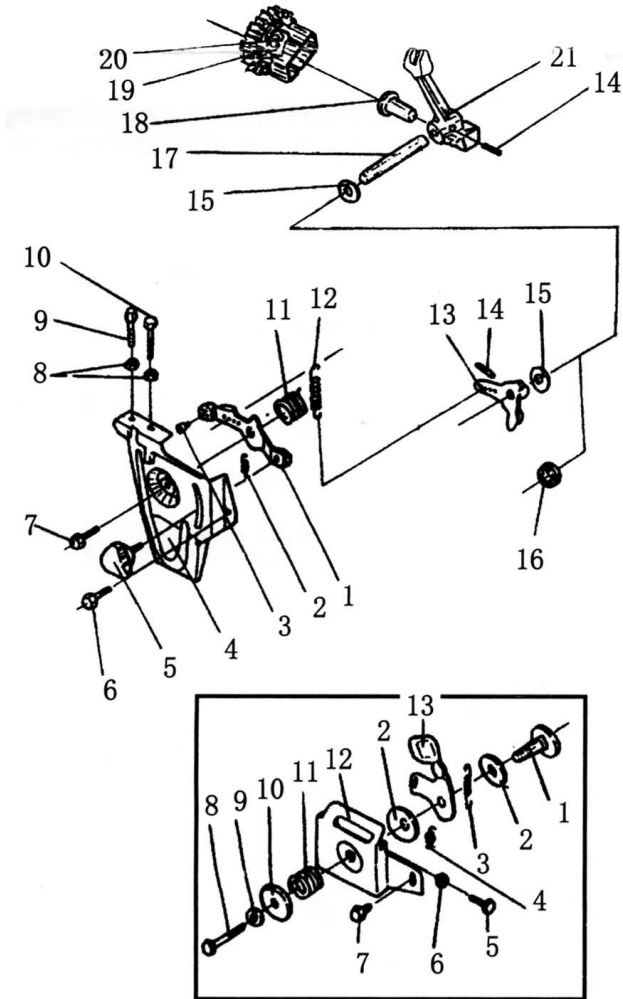

Rcf No.	Part No.	Description	Qty.
1	186F-11311	Control Handle	1
2	186F- 11006	Return Spring 11	1
3	186F-11312	Pull Rod Head	1
4	186F-11401	Handle Bracket	1
5	186F- 11301	Handle	1
6	GB5787-86	Bolt M6 ~ 14	1
7	GB5787-86	Bolt M6 x 18	1
8	GB6172-86	Nut M6	2
9	186F- 11403	Pull Bolt	1
10	186F- 11402	High Speed Limit Screw	1
11	186F- 11005	Return Spring I	1
12	186F- 11007	Governor Spring	1
13	186F-11100	Lever Fork Part	1
14	GB117-86	Pin B3 x 22	2
15	186F- 11003	Washer	2
16	186FG-11008	Lever Shaft Oil Seal	1
17	186F-11102	Lever shaft	1
18	186F- 11004	Tappet Speed Regulator	1
19	186F- 11001	Fly Block	2
20	186F- 11002	Fly Block Pin	2
21	186F-11101	Lever Fork	1
186FG			
1	186FG- 11303	Handle Shaft	1
2	186FG- 11302	Handle shaft Gasket	2
3	186FG-11012	Governor Spring	1
4	186FG-11005	Return Spring	1
5	186FG- 11307	High Speed Limit Screw	1
6	GB97.1-85	Washer6	1
7	GB5783-86	Bolt M6 x 12	1
8	GB5782-86	Bolt M6 x 45	1
9	GB6173-86	Nut M10 x 1.25	1
10	186FG- 11306	Bowl Cap	1
11	186FG- 11305	Spring	1
12	186FG- 11302	Handle Bracket	1
13	186FG-11301	Handle	1

(14) Recoil Starter Assembly

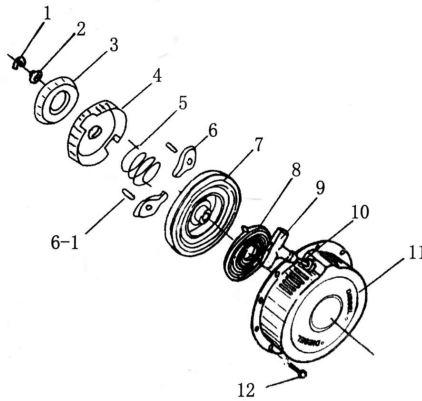

Ref No.	Part No.	Description	Qty.
1	GB6170-86	Nut M8	1
2	GB93-87	Washer 8	1
3	186F- 14002	Friction Plate	1
4	186F- 14004	Starter Ratchet Gland	1
5	186F- 14011	Return Spring	1
6	186F- 14008	Starter Katchet	2
6-1	186F- 14001-01	Starter Ratchet Axle	2
7	186F- 14001	Reel	1
8	186F - 14006	Spiral Spring	1
9	186F- 14007	Starter Handle	1
10	186F- 14005	Starter Rope	1
11	186F- 14100	Case Assem.	1
12	GB5787-86	Bolt M6 x 12	4

(15) Cooling Device Assembly

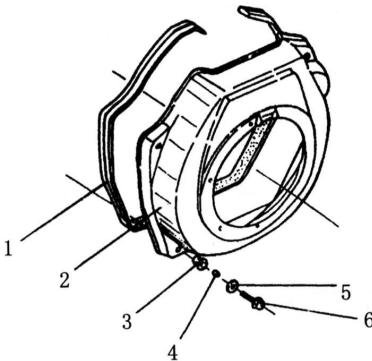

Ref No.	Part No.	Description	Qty.
1	186F- 17003	Shock Absorber Seat	1
2	186F- 17100	Fan Case Welded Assem	1
3	186F- 17002	Shock Absorber Bush	4
4	186F- 17001	Bush	4
5	GB96-85	Washer 6	5
6	GB5787-86	Bolt M6 x 22	5

APPENDIX 1.OVERALL AND INSTALLATION DIMENSIONS

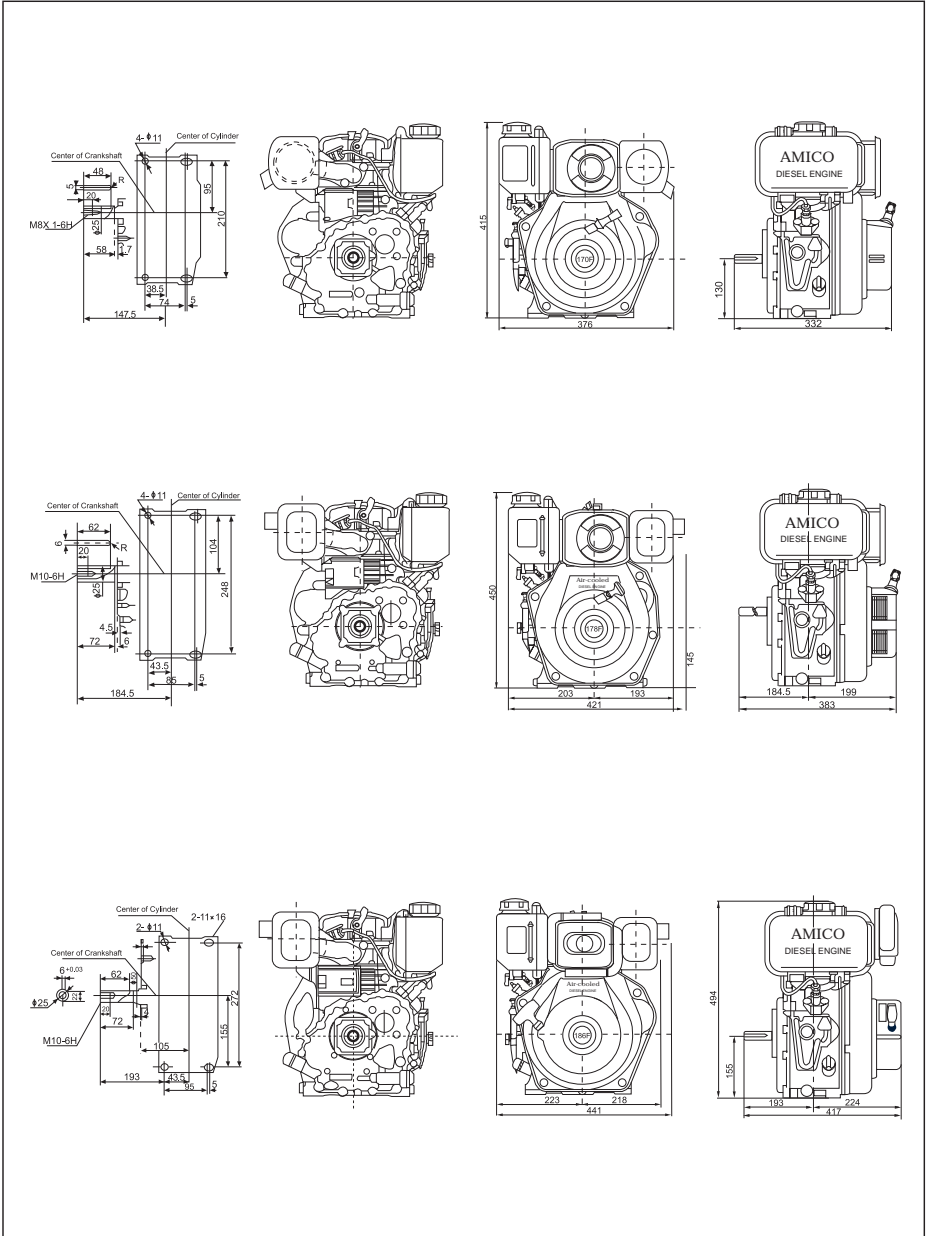

APPENDIX 2.PERFORMANCE CURVE & SIZES OF PTO FLANGES

MODEL	Crankshaft PTO		
	Keyway shaft	Thread Shaft	Taper Shaft
Application code	F1/F2	P1/P2	G1/G2
AHD170	<p>F1</p> <p>F2</p>	<p>P1</p> <p>P2</p>	<p>G1</p> <p>G2</p>
AHD178	<p>F1</p> <p>F2</p>	<p>P1</p> <p>P2</p>	<p>G1</p> <p>G2</p>
AHD186	<p>F1</p> <p>F2</p>	<p>P1</p> <p>P2</p>	<p>G1</p> <p>G2</p>

APPENDIX 3.SIZE OF OUTPUT SHAFT

MODEL	Camshaft PTO	Camshaft PTO	
	Keyway shaft	Crankshaft PTO	Crankshaft PTO
Application code	S		S
AHD170			
AHD178			
AHD186			

APPENDIX 3.Malfunction and remedy of diesel engine

3-1 The Cause and Remedy for the Engine Not Being Started

CAUSE	REMEDY
The weather is cold ,machine oil become more adhesive	Fill machine oil into crankshaft case after preheated. Fill machine oil into inlet manifold. Disassemble the connection belt of match machine and then start the diesel engine,stop the engine When the engine is heating and reassemble the belt, start the engine again.
Malfunction of fuel system.The fuel is mixed with water	Clean fuel tank filter and fuel pipe,change fuel.
The fuel become thickening and not easy to flow	Use the fuel as specified
There is air in the fuel system	Drain out the air and tighten each connector of fuel pipe.
Injection fuel is little or no,the spray is not good	Check the position of speed governor handle,clean spray nozzle,fuel pump,maintain or change the pump or nozzle if necessary.
Combustion is not complete	The spray nozzle is not good,delivery angle is not correct,gasket of cylinder head is leaked and the pressure of compression is not enough,remedy with its cause.
Diesel fuel delivery is interrupted	Diesel fuel is too little in the fuel tank fill the fuel into the fuel tank.If the fuel pipe and fuel filter are obstructed or leakage,remedy them.
Compression pressure is not enough in the cylinder,The nut of cylinder head is not tighten or gasket of cylinder is damaged or leakage.	Tighten the nut of cylinder head,according,to diagonal line sequence and standard requirement,check gasket of cylinder,if change the gasket it must tighten the nut of cylinder head once again after pre-run the diesel engine.

The gap of piston ring is too big because of wearing	Change the piston ring
Each gap of piston rings line up,which cause leakage	Set each gap of piston at angle of 120
The piston rings are sticked seriously or broken	Clean with diesel fuel or change rings.
Gas valves leakage	Grind the gas valves,if the vestige is too deep,please send factory to remedy.
The valve clearance is not correct	Adjust the clearance as specified.
The valve stem is clipped on guide pipe	Disassemble the gas valve and clean the stem and guide pipe.

3-2 Cause and Remedy for Not Enough Power of Diesel Engine

CAUSE	REMEDY
Malfunction of fuel system: parts obstruction of fuel pipeline and fuel filter	Check fuel switch,it must be opened fully. Clean fuel filter and fuel pipeline.
The pumping of fuel is not good	Maintain or change the damaged parts of fuel pump
Malfunction of nozzle: injection pressure is not correct	Adjust the injection pressure.
Spray hole carbon deposit	Clean.
Needle valve adhered	Clean or change.
Fitting is too loose between needle valve and needle valve body	Change.
Air filter is obstructed	Disassemble or clean or change the core of filter.
Speed is not high enough	Check the speed of diesel engine with tachometer Adjust the high speed limit screw.

3-3 Cause and Remedy for the Engine Stopping Automatically

CAUSE	REMEDY
Malfunction of fuel system: No fuel	Add fuel.
Fuel pipeline or filter is obstructed	Maintain or clean.
There is air in fuel system	Drain out the air.
Needle valve of nozzle adhered	Clean,grind the nozzle or change it if necessary.
Air filter is obstructed	Maintain or clean or brush off.
The load increase suddenly	Decrease the load.

3-4 Cause and Redemy for Exhaust with Black Smoke

CAUSE	REMEDY
Overload	Decrease the load,if working machine is not properly matched,change it.
Fuel Injection is not good	Check the injection pressure and spray condition and correct it,or change the nozzle if it is damaged.
Air is not enough or leakage	Clean the air filter,check the cause of leakage and remedy.

3-5 Cause and Remedy for Exhaust with Blue Smoke.

CAUSE	REMEDY
There is machine oil in cylinder	Check oil level,drain away the unnecessary machine oil
Piston.ring is clipped or worn,and its springiness is not enough or each.gap of ring turn to same direction to make the machine oil go up	Check,change the piston ring,and cross each gap position. Remedy or change.
The gap is too big between piston and cylinder	Remedy or change.
Valve and guide are worn	Change.

3-6 Cause and Remedy for Exhaust with White Smoke

CAUSE	REMEDY
There is water in diesel fuel	Clean the fuel tank and diesel filter,change diesel fuel.

3-7 Methods and Positions of Stopping to Check When the Engine's Malfunctioning

CAUSE	REMEDY
Speed is sometimes high, sometimes low	Check the speed governor system whether it is nimble. Whether there is air in fuel pipeline.
Abnormal sound suddenly happen	Check each movement part carefully.
Exhaust with black smoke suddenly	Check fuel system especially nozzle.
There is metal knocking sound rhythmically in the cylinder	The fuel delivery angle is too big,adjust it.

LIMITED WARRANTY

AMICO will repair or replace, free of charge, any part or parts of the generator that are defective in material or workmanship or both. Transportation charges on parts submitted for repair or replacement under this Warranty must be borne by purchaser. This warranty is effective for the time period and subject to the conditions provided for in this policy. For warranty service, find the nearest Authorized Service Dealer by contacting the place of purchase or AMICO THERE IS NO OTHER EXPRESSED WARRANTY. IMPLIED WARRANTIES, INCLUDING THOSE OF MERCHANTABILITY AND FITNESS FOR A PARTICULAR PURPOSE, ARE LIMITED TO ONE YEAR FROM PURCHASE, OR TO THE EXTENT PERMITTED BY LAW ANY AND ALL IMPLIED WARRANTIES ARE EXCLUDED. LIABILITY FOR CONSEQUENTIAL DAMAGES UNDER ANY AND ALL WARRANTIES ARE EXCLUDED TO THE EXTENT EXCLUSION IS PERMITTED BY LAW. Some states do not allow limitations on how long an implied warranty lasts, and some states do not allow the exclusion or limitation of incidental or consequential damages, so the above limitation and exclusion may not apply to you. This warranty gives you specific legal rights and you may also have other rights, which vary from state to state.

WARRANTY PERIOD

ENGINES	WITHIN U.S.A AND CANADA		OUTSIDE U.S.A. AND CANADA	
	CONSUMER USE	COMMERCIAL USE	CONSUMER USE	COMMERCIAL USE
DIESEL ENGINE	1 year or 1000 hours	1 year or 1000 hours	1 year or 1000 hours	1 year or 1000 hours

The warranty period begins on the date of the purchase by the first retail consumer or commercial end user, and continues for the period of time stated in table above. "Consumer use" means personal residential household use by a retail consumer. "Commercial use" means all other uses, including use for commercial, income producing or rental purposes. Once the engine has experienced commercial use, it shall thereafter be considered as a commercial use engine for purposes of this warranty.

A two-year or 1500 hour warranty applies to the emission control system on engines certified by EPA

IMPORTANT! WARRANTY REGISTRATION IS NECESSARY TO OBTAIN LIMITED WARRANTY ON OUR ENGINES. THE WARRANTY REGISTRATION CARD MUST BE RETURNED WITHIN 15 DAYS OF ORIGINAL PURCHASE FOR LIMITED WARRANTY TO BE VALID."

About Your Product Warranty

AMICO welcomes warranty repair and apologizes to you for being inconvenienced. Any Authorized Service Dealer may perform warranty repairs. Most warranty repairs are handled routinely, but sometimes warranty service may be inappropriate. For example, warranty would not apply if an engine is damaged because of misuse, lack of routine maintenance, shipping, handling, warehousing and improper installation. Similarly, warranty is void if the serial number on the engine has been removed or if the engine has been altered or modified. If a customer differs with the decision of the Service Dealer, an investigation will be made to determine whether the warranty applies. Ask the Service Dealer to submit all supporting facts to his Distributor or the factory for review. If the distributor or the factory decides that the claim is justified, the customer will be fully reimbursed for those items that are defective. To avoid misunderstanding, which might occur between the customer and the dealer, listed below are some of the causes of engine failure that the warranty does not cover.

Normal wear:

Engines and generators, like all mechanical devices, need periodic parts service and replacement to perform well. Warranty will not cover repair when normal use has exhausted the life of a part of an engine.

Improper maintenance:

The life of an engine or your equipment depends upon the conditions under which it operates, and the care it receives. Some applications, such as tillers, pumps, and rotary movers, are very often used in dusty or dirty conditions, which can cause what appears to be premature wear. Such wear, when caused by dirt, dust, spark plug cleaning grit, or other abrasive material that has entered the engine because of improper maintenance is not covered by warranty. This warrant covers engine related defective material and/or workmanship only, and not replacement or refund of the equipment to which the engine may be mounted. Nor does the warranty extend to repairs required because of:

1. ROBLEMS CAUSED BY PARTS THAT ARE NOT ORIGINAL OUR PARTS.
2. Equipment controls or installations that prevent starting, cause unsatisfactory. engine performance manufacturer.
3. Leaking carburetors, clogged fuel pipes, sticking valves, or other damage, caused by using contaminated or stale fuel. (Use clean, fresh*lead-free gasoline.)
4. Parts which are scored or broken because an engine was operated with insufficient or contaminated lubricating oil, or an incorrect grated of lubricating oil (check oil level daily or after every 8 hours of operation. Refill when necessary and change at recommended intervals.) Engine damage may occur if oil level is not properly maintained. Read Operation & Maintenance Instructions.
5. Repair or adjustment of associated parts or assemblies such as clutches, transmissions, remote controls, ect., which are not manufactured by US
6. Damage or wear to parts caused by dirt, witch entered the engine because of improper air cleaner maintenance, re-assembly, or use of a non-original air cleaner element or cartridge. Read Operating & Maintenance Instructions.
7. Parts damaged by over-speeding, or overheating caused by grass, debris, or dirt, which plugs or clogs the cooling fins, or flywheel area, or damage caused by operating the engine in a confined area without sufficient ventilation.

- 8.Engine or equipment parts broken by excessive vibration caused by a loose cutter blades unbalanced blades or loose or unbalanced impellers, improper attachment of equipment to engine crankshaft, over-speeding or other abuse in operation.
- 9.A bent or broken crankshaft, caused by striking a solid object with the cutter blade of a rotary lawn mower, or excessive v-belt tightness.
- 10.Routine tune-up or adjustment of the engine.
- 11.Engine or engine component failure, i.e., combustion chamber, valves, valve seats, valve guides, or burned starter motor winding, caused by the use of alternate fuels such as, liquefied petroleum, natural gas, altered gasoline's, ect.

Warranty is available only through service dealers, which have been authorized by our company .Contact place of purchase or our company for Service Dealer near you.

PRODUCT REGISTRATION CARD

For more efficient customer service, please fill out the information below and mail to our produce Warranty and Registration Division:

Amico International Corp.

4825 Gregg Road,

Pico Rivera, CA 90660, U.S.A

Tel: 562-908-0088 Fax: 562-908-1899

Website: www.amicousa.com

Model No. _____ Engine Serial No. _____ Purchase Date. ____ / ____ / ____

Purchased from: Retail location Private Consumer Other _____

Name _____

Address _____

Telephone w/area code _____ Purchase Price _____

Purchased: NEW or USED

Consumer information :

Name _____ Telephone w/area code _____

Address _____ Suite or Apt No. _____

City _____ State _____ Zip Code _____

Country _____

Are you a: Business or Residence

Product Usage Information :

How often will you use this product?

Everyday Periodically

Emergency use only Other _____

What type of application will you use this produce in ?

Heavy Commercial Moderate Commercial

Light Commercial Tradeshows

Heavy residential Moderate Residential

Light Residential Camping, backpacking

Other _____

IMPORTANT INFORMATION

It is critical to your warranty that the original point of sales receipt be retained by current consumer, and in order to comply with our product Warranty Statement you must return this registration card within 15 days of original purchase. Product warranty is valid from original date of purchase.

List for comments from users

		Date of Manufacture	
Name of user		Model Number	
Address of user		Occupation	
Place of purchase			
Packaging conditions			
Operating conditions			
Parts Conditions			
Malfunction problem			
Opinions or suggestions			

Note: Please mail the above card to:
Amico International Corp.
4825 Gregg Road,
Pico Rivera, CA 90660, U.S.A
Tel: 562-908-0088 Fax: 562-908-1899
Website: www.amicousa.com